

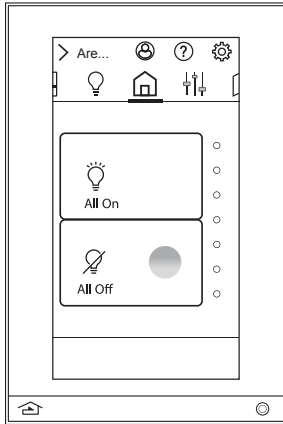

## EQ41-LCAP • Les Numéros de Catalogue • Los Números de Catálogo:





Country of Origin: Made in China • Pays d'origine: Fabriqué en Chine • País de origen: Hecho en China



## OVERVIEW

Legrand's Equinox 41-LCAP LCD Touchscreen is designed to be installed in a single gang box and is a similar size to traditional keypads. Legrand's Equinox 41-LCAP uses self discovering widgets, eliminating countless hours of tedious programming. Navigate and control, with real time feedback. Widgets may be further personalized or additional controls setup directly on the touchscreen, by selecting the Settings Menu in the upper right hand corner of the screen with the gear symbol . In the settings menu the administrator of the system can change or create the following: scenes, event timers, schedules, etc. The interface uses intuitive gestures; swipe left and right to change widgets, touch and release for normal button operation, or press and hold for dim-cycle, shade controls, etc.

## FEATURES AND OPERATION OVERVIEW

- Vertical screen orientation displays main room button screen, as a default, with all widgets appropriate for the space where the touchscreen is located, in the widget bar
- Equinox platform provides built-in widgets using Legrand's proprietary auto discovery widgets for fast automatic screen design
- Equinox 41-LCAP incorporates consistent user experience interface. In-wall touchscreens, tablets and smart phones use the same user interface
- Power over Ethernet, PoE or PoE+
  - PoE optional Ethernet 4 Port PoE Injector part number DA2400 or COM-POE-SWITCH
- Communicates over Ethernet, via Ethernet Bus
- Firmware upgradeable over Ethernet from Design Center
- Built-in ambient light sensor for "Active," AUTO mode screen brightness
- Built-in proximity activation, 6" maximum, may be programmed to execute a task with a hand wave across front of station
- Dual operation mechanical buttons, bottom left and right;
  - Left  navigates to default widget
  - Right  may be programmed with a task from Design Center
- Three types of users are supported on the system. Using a variety of users you can limit what is available to specific individuals as well as limit permissions.
  - Administrators - All permissions and visibility into the system. Only one system-wide administrator can be assigned whose password is set up at system startup. The admin password can be created or changed from within Equinox view. It is not dependent on the first time initialization screen.
  - Managed Users - A password protected user who can have a wide variety of permissions granted to them, including the creation of other users. There is no limit to the number of managed users.
  - Guest Users - Recommended to be the default user on all screens in public areas, guest users cannot make any changes to the system and have no permissions to set. They cannot be password protected.
- Top of screen displays:
  -  - Administrator/user details
  -  - Access help topics
  -  - Manage settings including appearance, access/permissions, areas and rooms, devices, events, groups, repair, schedules, scenes, and systems
- Main screen automatically displays widgets based on Design Center project file (order may be changed in user/settings directly from the app) including shades, lighting, home, and scenes
- Raise/lower dimmable loads, shades, hue and intensity settings using sliders

---

## FEATURES AND OPERATION OVERVIEW *(continued)*

---

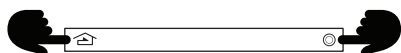

**NOTE:** If buttons are held in too long, the screen will boot to *service mode*, and will not load the application code. Repeat manual reboot – without holding buttons to long – to clear this mode.

- Station reset – simultaneously press and hold both mechanical buttons for three seconds until the screen goes dark, then release
- Station reset into *Service Mode* – simultaneously press and hold both mechanical buttons for ten seconds
  - Service mode is automatically used when updating firmware from Design Center
  - If the application code is corrupt it may cause the screen to lock, preventing Design Center from updating or reloading the firmware. Use this option to reboot the screen to service mode allowing Design Center to update the corrupted firmware.
  - To manually exit *Server Mode* use the *Station Reset* option (above)

---

## SPECIFICATIONS

---

Description	Specification
Dimensions, HWD (at wall surface)	4.9" x 3.44" x 0.44" (124mm x 87mm x 11mm)
Dimensions, HWD (overall)	4.9" x 3.44" x 1.1" (124mm x 87mm x 28mm)
Finished Weight	8.8 oz. or 249.5g
Power	Ethernet with PoE, PoE+, 5W
Wiring Connections	Communication and power: PoE/PoE+ via Ethernet RJ45
Surge Suppression	Yes
Maximum Gangs	Single gang only
LCD Button Status	Automatic (white = off, orange = on)
Mounting	US/European style, single gang, wall boxes or low-voltage brackets
Addressing	Self-addressing through software
Finish	Trim: Titanium, Touchscreen: Black glass
Glass Surface	Chemically strengthened
Ambient Operating Temperature	32-95°F (0-35°C)
Ambient Operating Humidity	5-95% non-condensing
CE/FCC Compliant	Yes

---

## SYSTEM REQUIREMENTS

---

Equinox 41-LCAP is compatible with InFusion Design Center version 3.8 software or higher. For new projects it is recommended that firmware and software be kept to the most current release.

---

## INSTALLATION

---

Installation of Legrand products should be performed or supervised by a certified Legrand installer. The Equinox 41-LCAP touchscreen installs into US/European style, single gang, wall boxes or low-voltage brackets. Connect to local network via PoE/PoE+ RJ45 Ethernet connection.

## INSTALLATION OVERVIEW

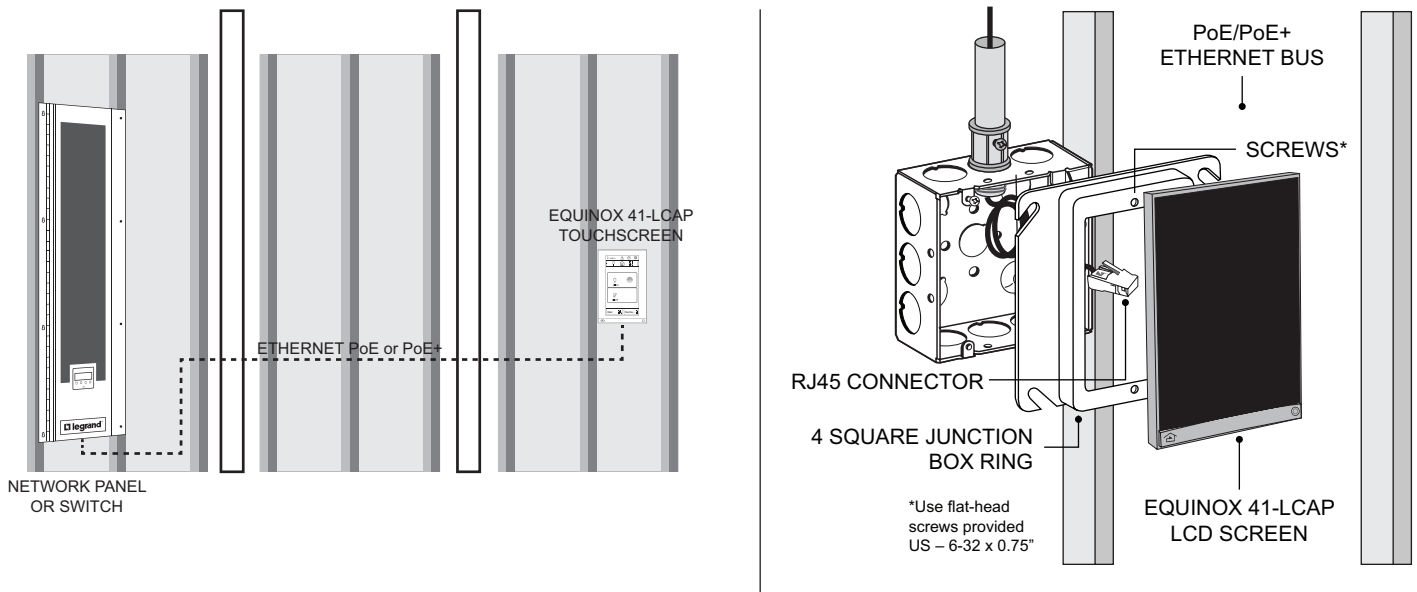

\***Ethernet Bus:** Power and communication; Ethernet, PoE or PoE+, (Optional) - Ethernet 4 Port PoE Injector (part# DA2400)

## EQUINOX 41-LCAP STATION INSTALLATION STEPS

1. Run PoE Ethernet bus to four square junction box
2. Install ring with screws provided (figure A)
3. Connect RJ45 to station
4. Install station by rotating (figure B) and connecting the top first. Press station in and hold on bottom center while securing the hex screw with provided allen wrench (figure C)

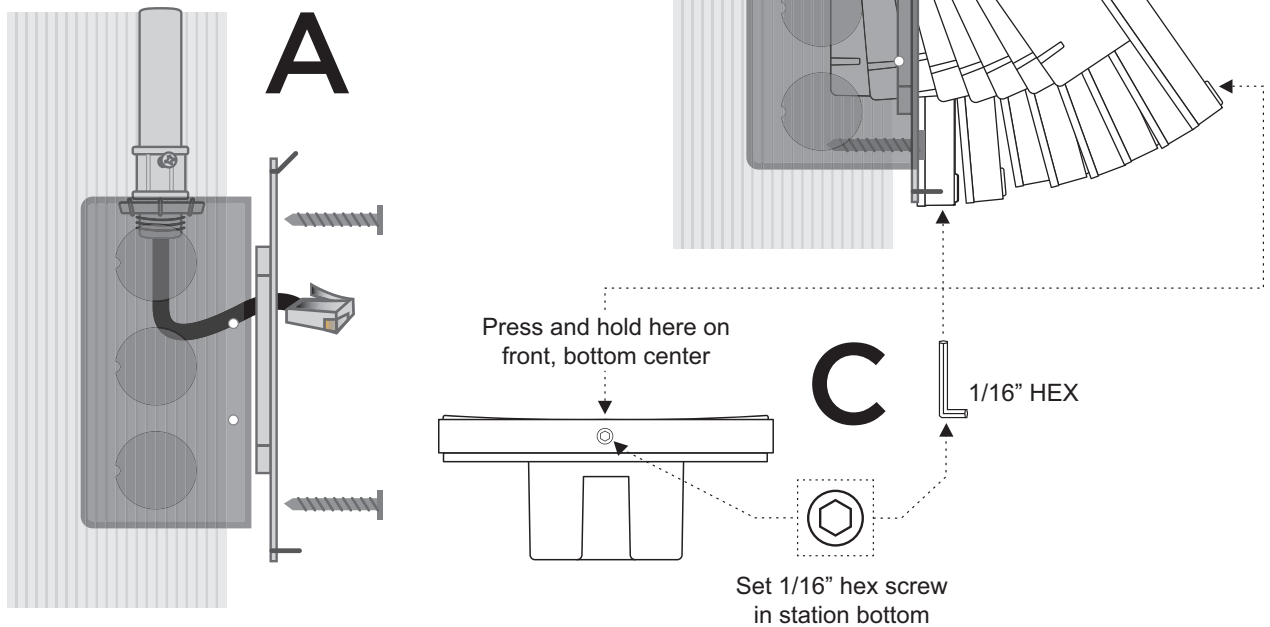

---

## CONFIGURATION

---

1. Connect PoE Ethernet Bus
  2. Add the Equinox 41-LCAP station to your project from the **Vantage Objects: Touchscreens** folder
  3. Highlight station in Design Center; click **Configure Stations**
    - In **Settings | System Preferences | General Preferences**, make sure **Exclude Ethernet Bus when configuring stations** is not checked
  4. When station displays **configure mode, touch to configure**, tap station  
- OR -
  5. The station may also be configured by typing the serial number in the project file. Using this method the station will be configured when the system is programmed.
- 

## FIRST TIME SETUP

---



**1. First Time Setup:** Click on *Create Admin Password* to establish a custom password. Using the keyboard, type in a password and press check ✓ to confirm.

**2.** Once the Admin Password is established, press *Initialize System* to access the current default view with all on/all off control.

---

## DEVICE SETTINGS OVERVIEW

---

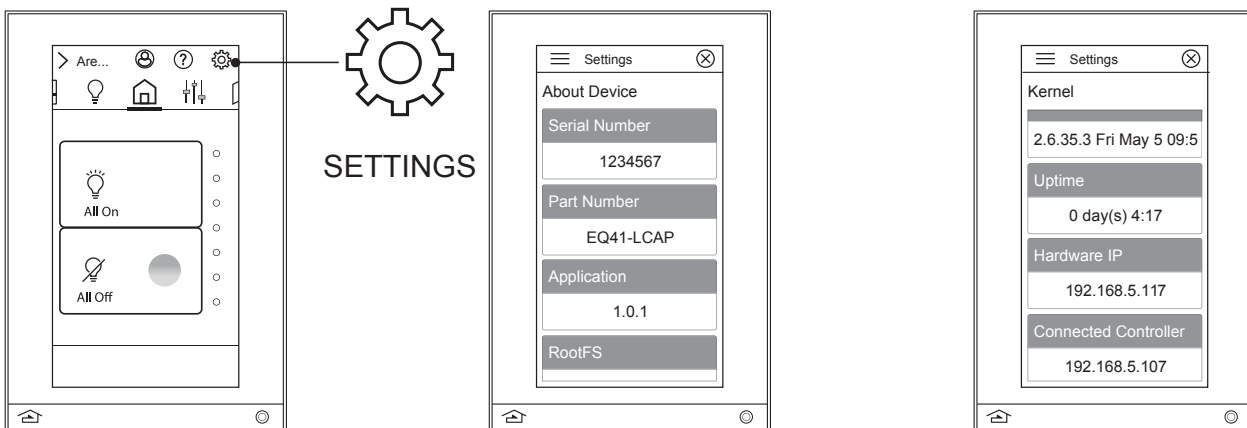

**1.** Access the main settings panel by clicking on the gear icon in the top right screen

**2. About** - Discover information about the Equinox 41-LCAP including serial number, part number, and application edition

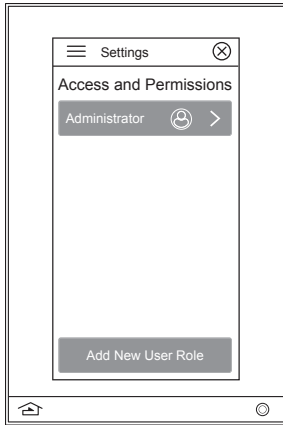

Also, identify the connected controller IP address

## DEVICE SETTINGS OVERVIEW (continued)

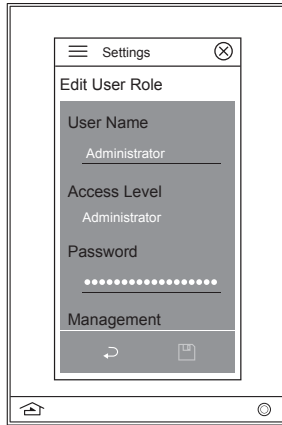

**3. Access and Permissions** - Edit all user accounts and passwords within this screen.



By pressing *Administrator*, access user role edit screen to set user name, access level, password, manage view order, default view, and startup preferences. To save, click the  icon or  to return to the main area and rooms menu.

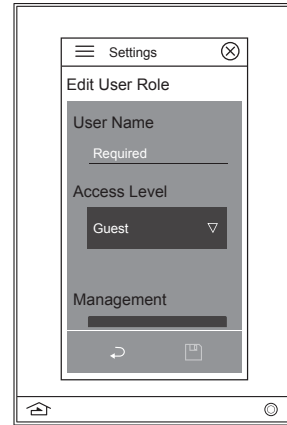

Or select *Add New User Role* to define a user name, access level (guest or manager), manage permissions, views (shade, lighting, default, scene, partition), default view (shade, lighting, default, scene, partition, none), and startup preferences.

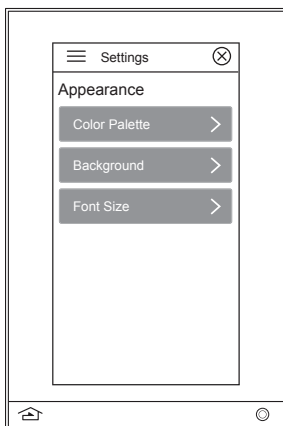

**4. Appearance** - Establish color palette, background color, and font size settings for optimal viewing.

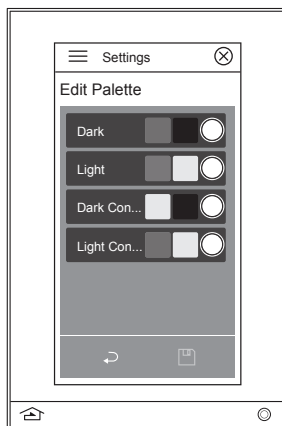

**5. Areas and Rooms** - Manage areas by selecting an area to adjust its name, access, included scenes, favorites, room presets, and startup location.

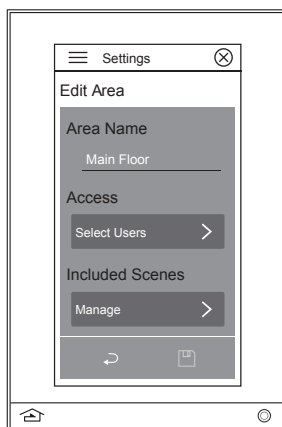

If rooms and partitions have previously been established in Design Center, further customize each area, including partitioned areas within this setting.

## DEVICE SETTINGS OVERVIEW (continued)

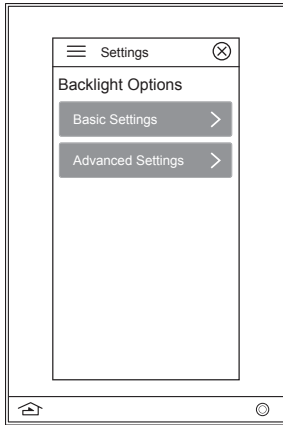

**6. Backlight** - Adjust the screen timeout, and active/inactive brightness of the Equinox 41-LCAP screen through basic and advanced settings.

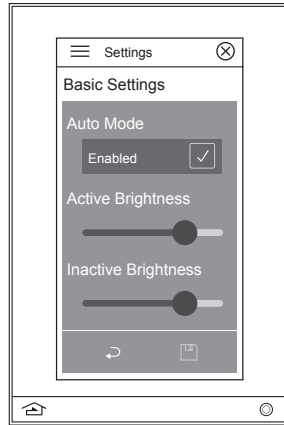

Basic settings include enabling auto mode which allows control for inactive brightness and screen timeout. When disabled, active brightness becomes controllable.

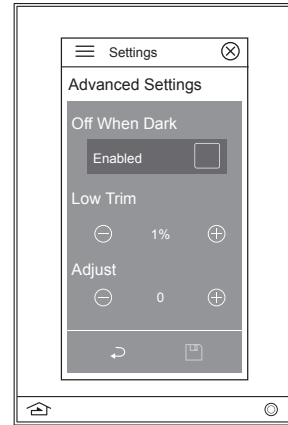

Advanced settings enables the touchscreen to go off when dark and allows the ability to set low trim and adjust levels.

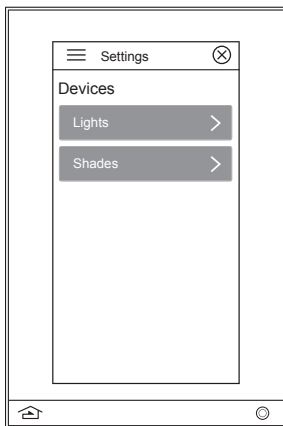

**7. Devices** - Manage devices such as lights and shades in each established area and their respective loads and shades or shade groups.

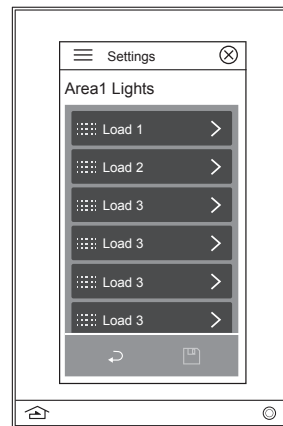
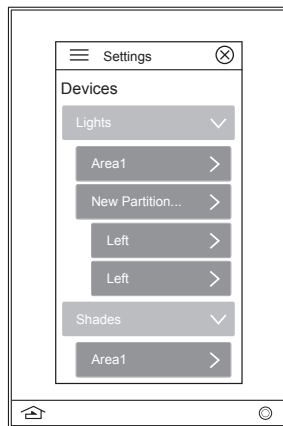

Additional levels of editing allow for load naming, user access, and schedule editing. Press to return to the previous screen. Upon completion, press to save changes.

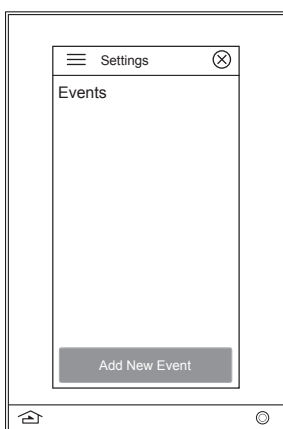
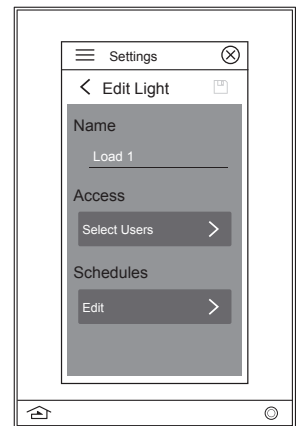

**8. Events** - An event starts a scene at a specific time and/or date interval: hourly, daily, weekly, monthly, or yearly. Events occur automatically at their occurrence time unless they have been skipped or disabled. Events require both an occurrence as well as an action. Depending on the occurrence type, specific times and dates can be selected for the event to run. Establish new events with name, scheduled recurrence, actions, next occurrence and enable other events. Screen levels provide further editing by type, intervals, and range restriction enabling.

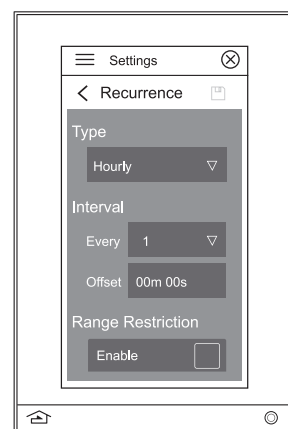
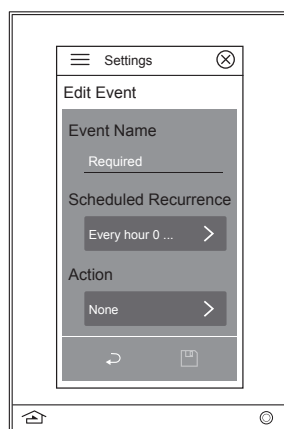

## DEVICE SETTINGS OVERVIEW (continued)

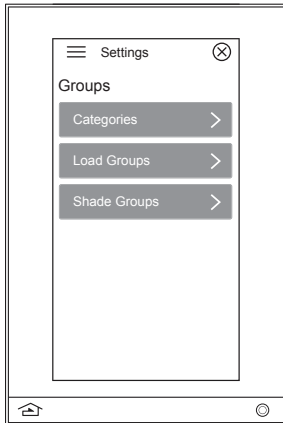

**9. Groups** - Control groups through categories, loads, and shades.

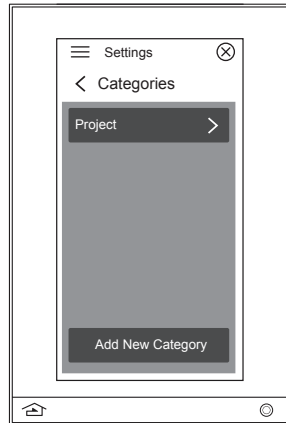

Create and manage categories to your specific project

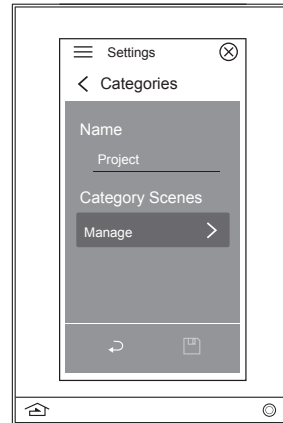

Second and third levels allow creation and management of load and shade groups.

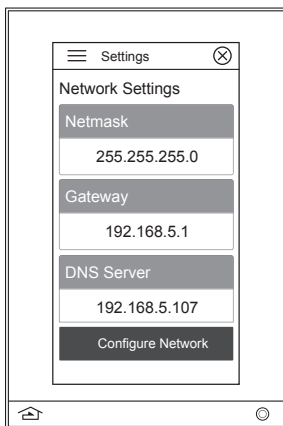
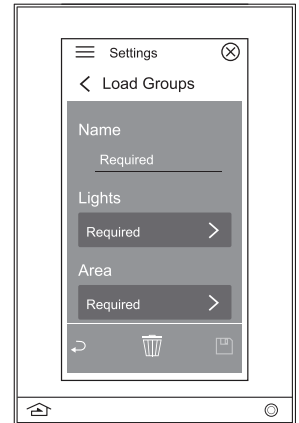

**10. Network** - Discover the current network settings of Mode, IP Address, Netmask, Gateway, and DNS Server.

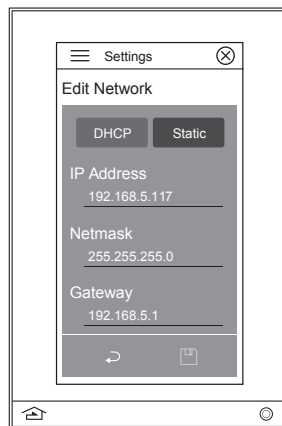

Configure the network through DHCP or select Static settings to manually enter the IP Address, Netmask, Gateway, or DNS Server addresses.

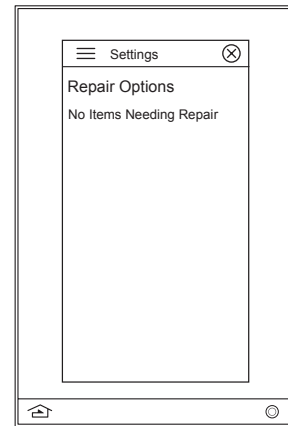

**11. Repair** - Check status of items needing repair

---

## DEVICE SETTINGS OVERVIEW (continued)

---

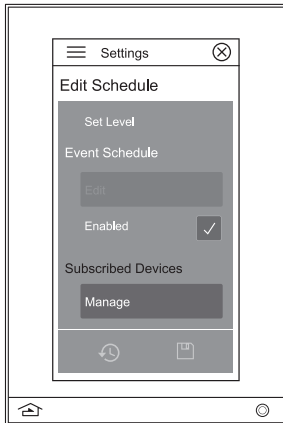

**12. Schedules** - A schedule sets a specific state on selected loads or shades based on the day of the week and time of the day. Rename an event and change subscribed devices through the schedule setting.

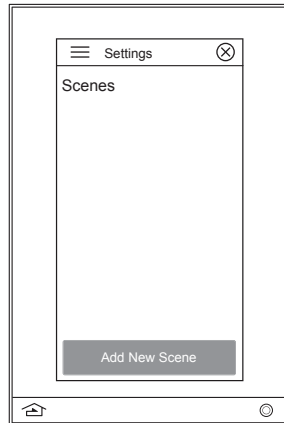

**13. Scenes** - A scene is a series of actions. Scenes are activated from the scene widget or when they have been set as a favorite. You are unable to activate them from this screen.

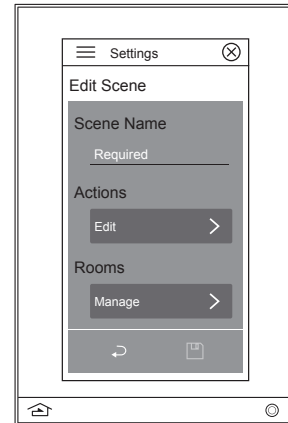

Editing levels allow scenes to be defined by name, action, room management, user access, and project category. They can also be created with combinations of certain actions that are available to your system.

---

## WIDGETS OVERVIEW

---

Program complete system control including shades, lighting, home, scenes, and divide/combine. For detailed information about all widgets and settings, refer to the widget instructions install pdf on the dealer site.





## MULTI-VIEW LINE DRAWING

### CLEANING

- Dampen a soft cloth in water and wring-out to barely damp
- Use a light buffing motion to wipe clean
- Do not take the station apart
- **Never** spray station with any cleaners

### NOTE:

Please reference local and NEC codes for appropriate electrical and communication install methodology

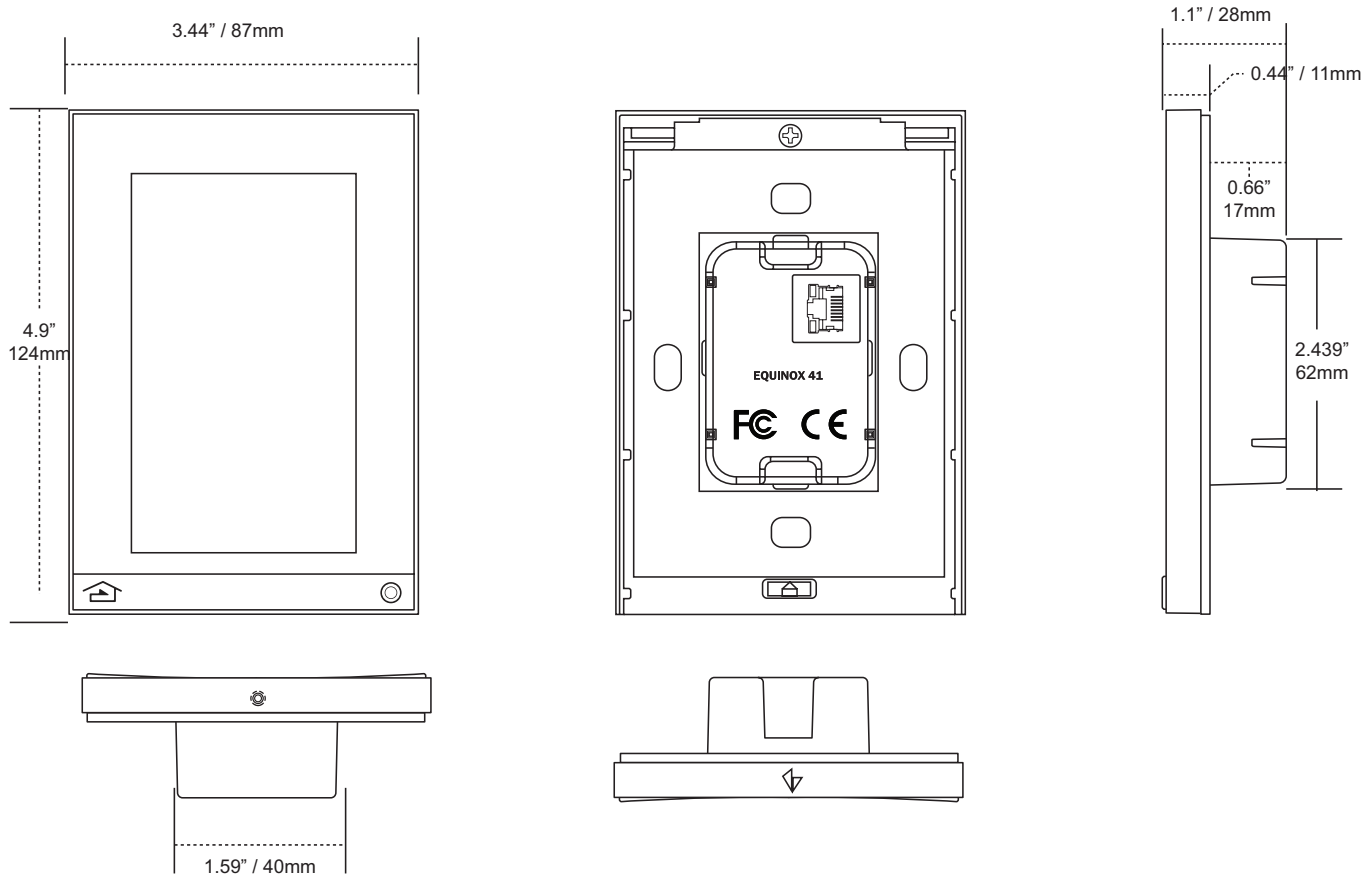

### MOUNTING PLATE

Use flat-head screws provided to mount the mounting plate.  
Do not bend mounting plate.

**CAUTION:** Pan head screws will not allow the station to fit snugly to the wall and may damage electronics Use screws supplied:  
2 each: US: VHC-01090-SCREW,  
6-32 x 0.75" P-FH, ZINC

#### WARRANTY INFORMATION

Wattstopper warrants its products to be free of defects in materials and workmanship for a period of three (3) years. Touchscreens are warranted for 90 days. There are no obligations or liabilities on the part of Wattstopper for consequential damages arising out of, or in connection with, the use or performance of this product or other indirect damages with respect to loss of property, revenue or profit, or cost of removal, installation or reinstallation.

#### INFORMATIONS RELATIVES À LA GARANTIE

Wattstopper garantit que ses produits sont exempts de défauts de matériaux et de fabrication pour une période de trois (3) ans. Les écrans tactiles sont garantis pendant 90 jours. Wattstopper ne peut être tenu responsable de tout dommage consécutif causé par ou lié à l'utilisation ou à la performance de ce produit ou tout autre dommage indirect lié à la perte de propriété, de revenus, ou de profits, ou aux coûts d'enlèvement, d'installation ou de réinstallation.

#### INFORMACIÓN DE LA GARANTÍA

Wattstopper garantiza que sus productos están libres de defectos en materiales y mano de obra por un período de tres (3) años. Las pantallas táctiles están garantizadas por 90 días. No existen obligaciones ni responsabilidades por parte de Wattstopper por daños consecuentes que se deriven o estén relacionados con el uso o el rendimiento de este producto u otros daños indirectos con respecto a la pérdida de propiedad, renta o ganancias, o al costo de extracción, instalación o reinstalación.