



Wattstopper®

Occupancy and Light Level Sensor for Indoor/Outdoor Use
Low Voltage • Fixture Mount (version 3)

No: 24040 – 07/18 rev. 2

Installation Instructions • Instructions d'Installation • Instrucciones de Instalación

Catalog Number • Numéro de Catalogue • Número de Catálogo: FS-305-D

Country of Origin: Made in China • Pays d'origine: Fabriqué en Chine • País de origen: Hecho en China

SPECIFICATIONS

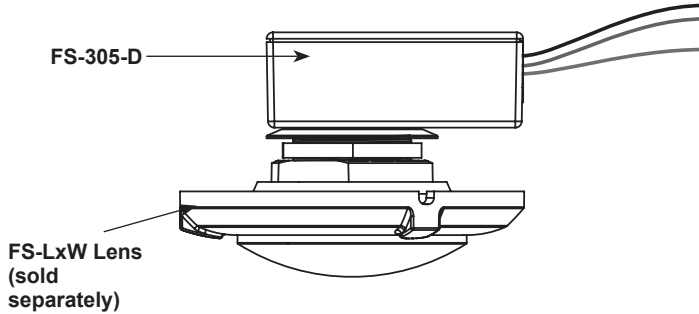

Voltage	12-30VDC
Adjustments/Settings	
Time Delay	30 seconds — 30 minutes
Factory Setting	12 minutes
High Level	10V
Low Mode.....	1-5V
Factory Setting	1V
Wiring	+24V, control, common
Current Consumption	maximum 6.5mA @ 24VDC
Coverage	
FS-L2W Lens @ 8' height	48' diameter
FS-L3W Lens @ 20' height	40' diameter
FS-L6 Lens @ 8' height	20' diameter
FS-L7W Lens @ 40' height	100' diameter
Operating Temperature	-40°F (-40°C) to 131°F (55°C)
Dimensions	
Throat.....	1.14" diameter (28.8mm)
Collar.....	1.28" diameter (32.6mm)
Lens Pipe Length	0.38" (9.6mm)
Body	1.38" x 2.35" x 0.88" (35mm x 59.5mm x 22.7mm)

OPEN DEVICE for installation in the Listed Enclosure per Installation Instructions.

DESCRIPTION AND OPERATION

The FS-305-D occupancy sensor dims lighting from high to low based on occupancy levels. This slim, low-profile sensor is designed for installation inside the bottom of a light fixture body. The PIR lens connects to the FS-305-D through a 1 1/8" diameter hole in the bottom of the fixture.

The sensors use passive infrared (PIR) sensing technology that reacts to changes in infrared energy (moving body heat) within the coverage area. Once the space is vacant and the time delay elapses (adjustable from 30 seconds to 30 minutes), lights will go to low mode. Sensors must directly "see" motion of an occupant to detect them, so careful consideration must be given to sensor placement. Avoid placing the sensor where shelving or other obstructions may block the sensor's line of sight.

The FS-305-D operates between 12-30VDC with Wattstopper class 2 power packs. It is designed for installation in a light fixture.

OUTDOOR USE AT THE SENSOR COLLAR PART ONLY WHEN (SENSOR COLLAR PART EXPOSED AND) INSTALLED AT THE SPECIFIC LOCATION PER INSTALLATION INSTRUCTIONS WITH A LISTED OUTDOOR ENCLOSURE.

INSTALLATION AND WIRING



WARNING
TURN THE POWER OFF AT THE CIRCUIT BREAKER
BEFORE INSTALLING THE SENSOR.



1. Install the FS-PP power pack as described in the instructions provided with the unit.
2. Determine an appropriate mounting location inside the light fixture for the FS-305-D. Allow a minimum distance of 1.3" (33mm) from the center of the sensor collar to the edge of the fixture.
3. Use a 11/8" (29mm) bit to drill a hole through the sheet metal in the bottom of the fixture.
4. From the inside of the fixture, insert the FS-305-D lens pipe through the hole in the bottom of the fixture. Install the sensor face down, parallel to the mounting surface. Hand tighten the Lens securely against the outside of the fixture. If necessary, use the Tightening Ring, with or without the metal washer (provided), as a spacer on either side of the fixture wall.
5. Connect control, load and supply wires as shown in Figure 2.
6. Restore power from the circuit breaker.

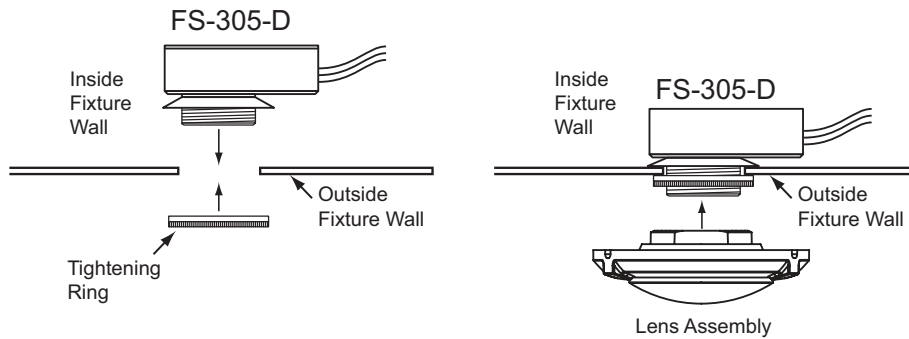

Fig 1: FS-305-D mounting in light fixture

NOTE: The Outside Fixture Wall thickness should be between 0.032" and 0.10" (0.82mm and 2.54mm) for optimal sensor mounting and security.

WIRING A SINGLE SENSOR

NOTE: See FS-PP v2 Instructions for load wiring

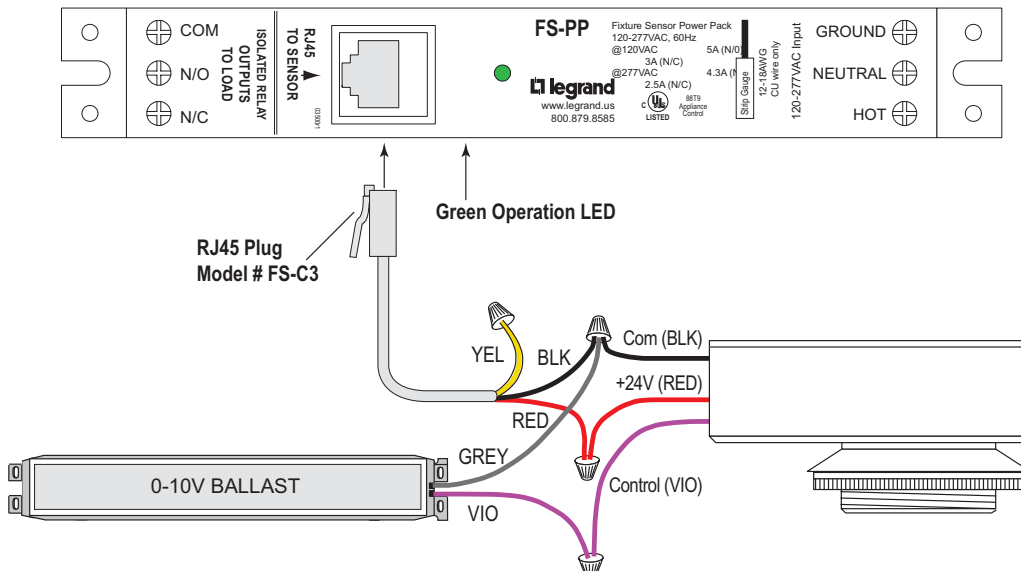

Fig 2: FS-305-D wiring

LOW MODE FEATURE

The Low Mode feature will dim the lights to a selected level, when the space becomes unoccupied. This selectable mode ranges from 1V to 5V.



CAUTION



**DO NOT OVERTURN TRIMPOT WHEN ADJUSTING THE SENSOR.
DO NOT TOUCH THE SQUARE INFRARED DETECTOR
UNDER THE LENS ASSEMBLY.**

SENSOR ADJUSTMENT

The Low Mode and Time Delay adjustment trimpots are located under the lens assembly. The trimpots are accessed easily after the sensor is mounted in the fixture. Gently unscrew the lens assembly. Do not remove the thumbscrew collar; it holds the sensor in place on the fixture. Identify each trimpot.

Test Occupancy Sensor

1. Set Low mode to minimum (fully counter-clockwise, Factory setting) and Time Delay to minimum (fully counterclockwise). Put the lens assembly back onto the sensor.
2. Move out of the sensor's view. Lights will go into Low mode after 30 seconds.
3. Move into the controlled area. The red LED in the sensor lens should illuminate and the lights will go into High mode.

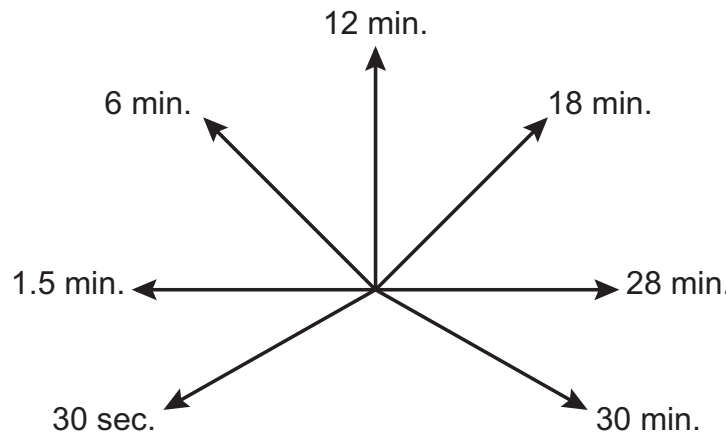
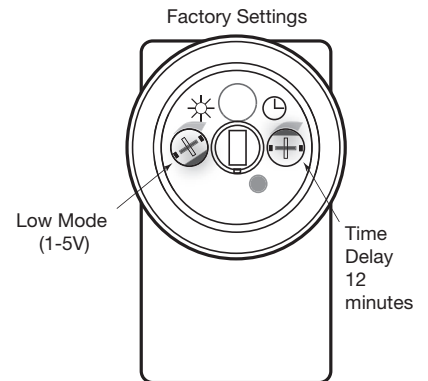

Fig 3: Time Delay Parameters

COVERAGE PATTERN

Density and range of the coverage pattern is determined by the type of lens and mounting height. See the FS-LxW Lens Module Coverage Guide for a description of the available coverage patterns.

TROUBLESHOOTING

Lights will not turn ON:

- LED does not flash - Check all wire connections.
- If lights still do not turn ON, call 800.879.8585.

Lights will not go LOW:

The time delay can be set from a minimum of 30 seconds (fully counter-clockwise) to a maximum of 30 minutes (fully clockwise). Ensure that the time delay is set to the desired delay and that there is no movement within the sensor's view for that time period.

- To quickly test the unit for proper operation, turn the time delay to minimum and move out of the sensor's view. Lights should go LOW after 30 seconds.
- If lights still do not go LOW, call 800.879.8585 for technical support.

Operation during Power-Up

During the sensor warm-up period, which can last up to a minute after initial power-up (or after a lengthy power outage), the load will remain ON until the selected time delay expires.

ORDERING INFORMATION

Catalog #	Description
FS-305-D	Fixture mount, High/Low, low voltage occupancy sensor
FS-PP v2	Fixture mount power pack
BZ-50	Power Pack with flying leads for connecting low voltage wires
BZ-150	Power Pack with flying leads for connecting low voltage wires, hold-on/hold-off inputs, plus manual or auto mode option
FS-C2	One 6" (152mm) cable with 3 flying leads at one end and a shielded RJ45 male connector at the other (use with FS-PP)  6" (152mm)
FS-L2W	360° lens, maximum coverage 48' diameter at 8' height
FS-L3W	360° lens, maximum coverage 40' diameter at 20' height
FS-L6	360° lens, maximum coverage 20' diameter at 8' height
FS-L7W	360° lens, maximum coverage 100' diameter at 40' height

Sensor and Lenses are White. The FS-L7W is also available in gray (FS-L7-G).

WARRANTY INFORMATION

Wattstopper warrants its products to be free of defects in materials and workmanship for a period of five (5) years. There are no obligations or liabilities on the part of Wattstopper for consequential damages arising out of, or in connection with, the use or performance of this product or other indirect damages with respect to loss of property, revenue or profit, or cost of removal, installation or reinstallation.

INFORMATIONS RELATIVES À LA GARANTIE

Wattstopper garantit que ses produits sont exempts de défauts de matériaux et de fabrication pour une période de cinq (5) ans. Wattstopper ne peut être tenu responsable de tout dommage consécutif causé par ou lié à l'utilisation ou à la performance de ce produit ou tout autre dommage indirect lié à la perte de propriété, de revenus, ou de profits, ou aux coûts d'enlèvement, d'installation ou de réinstallation.

INFORMACIÓN DE LA GARANTÍA

Wattstopper garantiza que sus productos están libres de defectos en materiales y mano de obra por un período de cinco (5) años. No existen obligaciones ni responsabilidades por parte de Wattstopper por daños consecuentes que se deriven o estén relacionados con el uso o el rendimiento de este producto u otros daños indirectos con respecto a la pérdida de propiedad, renta o ganancias, o al costo de extracción, instalación o reinstalación.