

HIGH-BAY LUMINAIRE INTEGRATED SENSOR

DALI-2SEN-LSPD-HB-LI

Luminaire Integrated Mounting



Passive Infrared (PIR) and
Photo Sensors

Detection Range up to 17 m (56 ft)

DESCRIPTION

The Wattstopper PLUS DALI-2 LS PD HB LI Sensor utilizes Passive Infrared (PIR) and Photo sensors to provide occupancy and light information.

The compact IP20 rated housing and a detection area optimized for installation heights up to 17 m (56 ft), make this sensor ideal for industrial and high-bay applications.

The DALI-2 LS PD HB LI Sensor is DALI-2 certified and communicates with the Wired Manger – DALI, a key component of the Wattstopper PLUS System.

FEATURES

- Designed for luminaire integration
- Mounting height up to 17 m (56 ft) makes this ideal for high-bay applications
- Compact design easily integrates into a luminaire housing
- DALI-2 certification

SPECIFICATIONS

- Voltage: 16 VDC, via DALI
- Current Consumption: 8mA
- Light Sensor Operating Range: Up to 1,500 lux (measured at sensor)
- Weight: 74 g (2.6 oz)
- Operating Temperature: -4° to 113°F (-20° to 45°C)
- Relative Humidity: 5% to 85%, non-condensing
- Certifications: CE, DALI2
- Complies with Electromagnetic Compatibility (EMC) Standards:
 - EN 55015, EN 61347-1, EN 61347-2-11, EN 61547,
 - EN 62386-101, EN 62386-103, EN 62386-303,
 - EN 62386-304, EN IEC 63000
- Environmental Suitability: IP20
- 5year warranty

DIMENSIONS

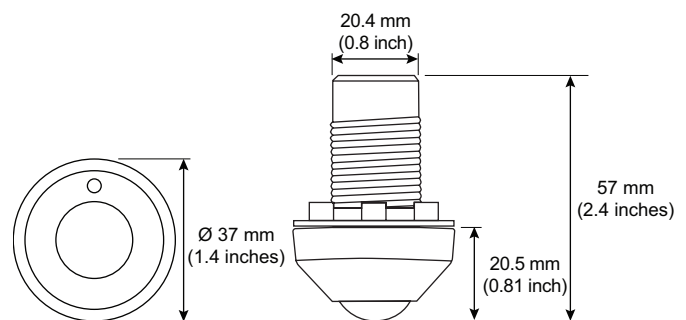

PROJECT		LOCATION/ TYPE	
---------	--	-------------------	--

SYSTEM OVERVIEW

Wattstopper PLUS enables you to control DALI devices. With any Wattstopper PLUS wired design, you get a reliable, lighting control system that can be installed quickly and easily.

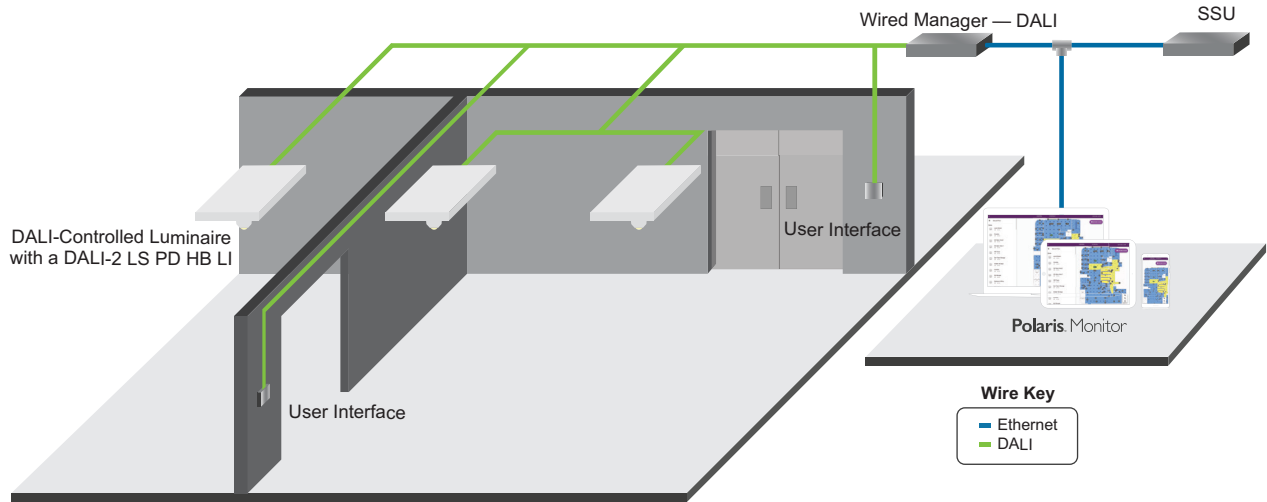

MOUNTING

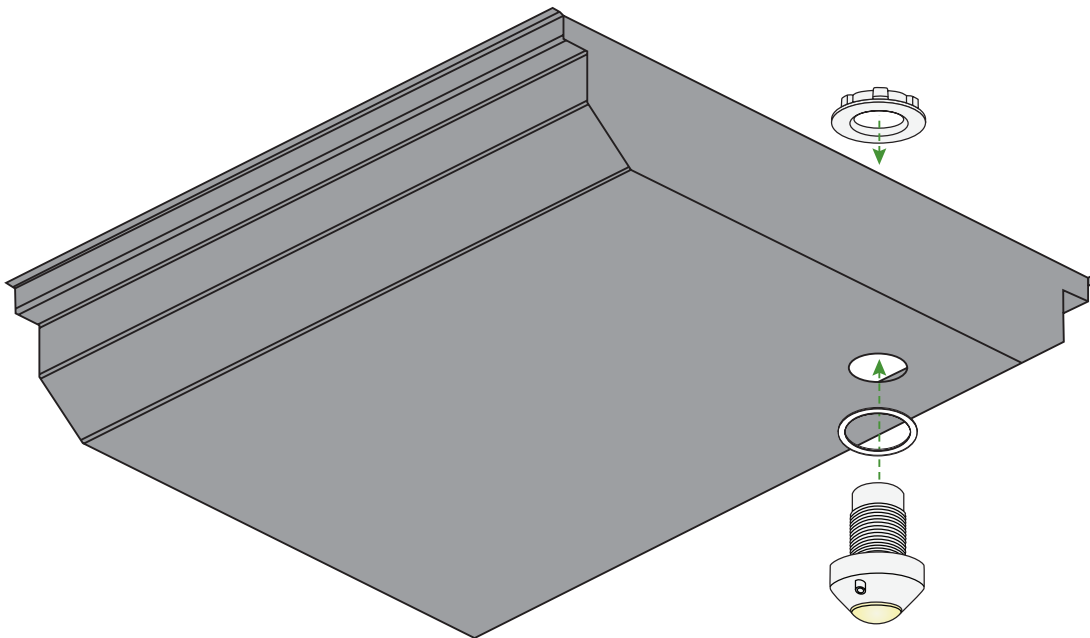

WIRING

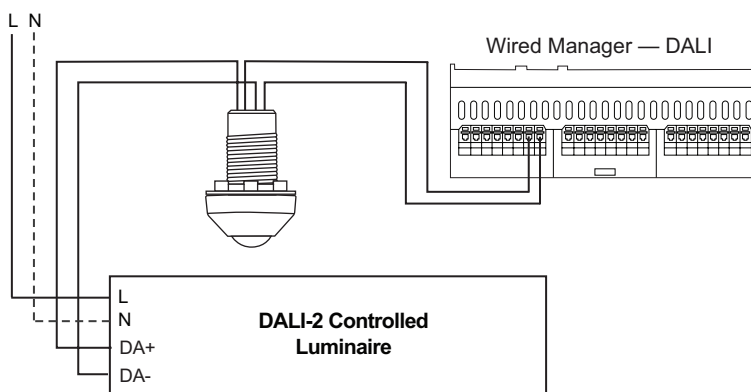

SENSOR DETECTION RANGE

Coverage Area

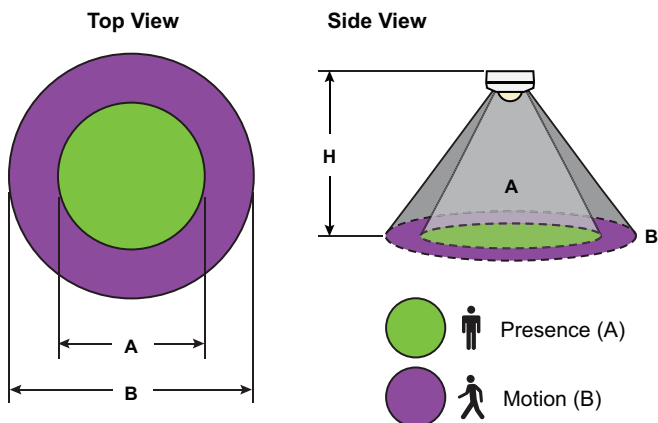

	Mounting Height			
	8 m (26.2 ft)	12 m (39.4 ft)	14 m (46 ft)	17 m (56 ft)
Detection Type	Detection Range			
Presence	8.5 m (28 ft)	12.7 m (42 ft)	14.5 m (48.5 ft)	18 m (59 ft)
Motion	9 m (29.5 ft)	14 m (45.9 ft)	16 m (52.5 ft)	18 m (59 ft)

ORDERING INFORMATION

Catalog #	Description	Communication Network
■ DALI-2SEN-LSPD-HB-LI	DALI-2 LS PD HB LI Sensor	Wired DALI-2