

1) If the cassette will be installed from the rear of the enclosure, disassemble the cassette front bezel: In your chosen splicing area, push the slide locks to the full rearward position (Figure 2), and then remove the front bezel (Figure 3). Bezel must be mounted into the target enclosure from the front (Figure 4) for rear cassette insertion. The alternate method would be to feed the pigtail through the drawer face opening and then install the cassette from the front side (Figure 5).

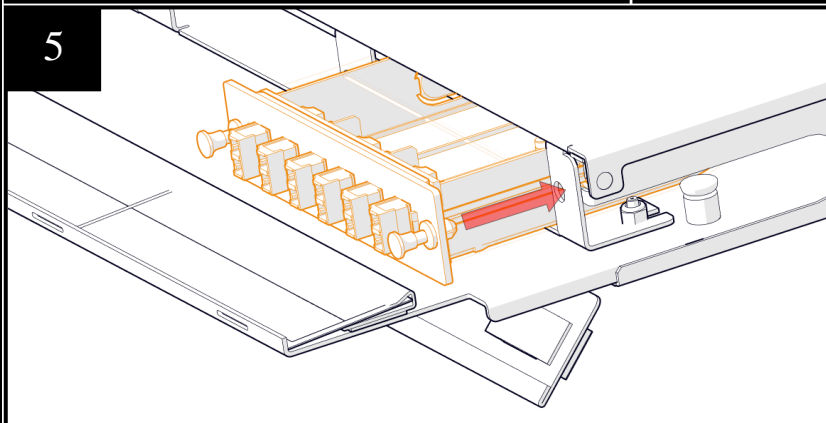

2) Tools and materials needed:

- a. Measuring tool
- b. Fiber stripper
- c. Fiber scissors
- d. Marker
- e. Isopropyl alcohol & lint free wipes
- f. Splice Sleeves (45mm long)
- g. Cleaver
- h. Fusion splicer

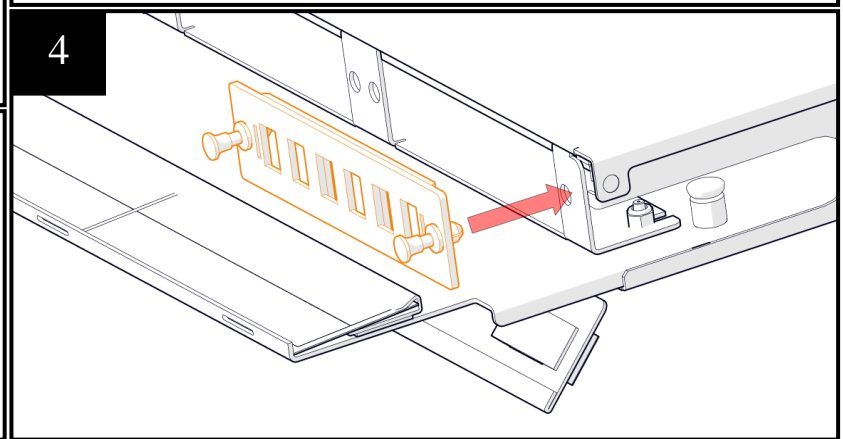
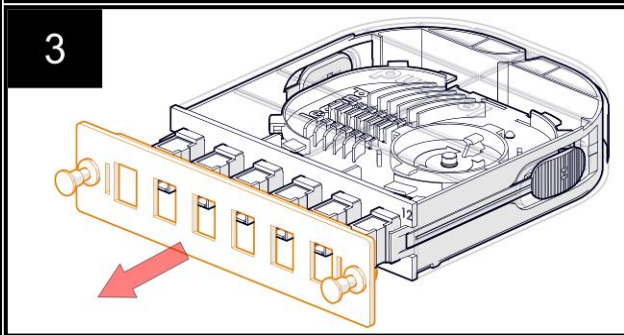
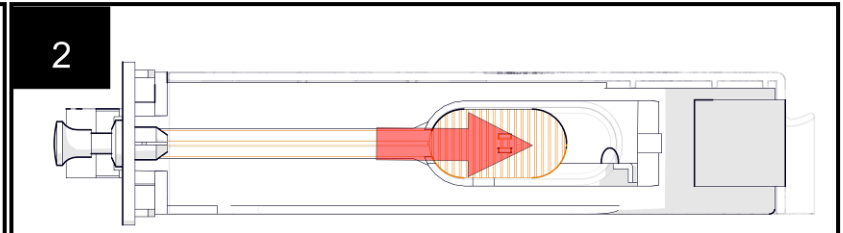
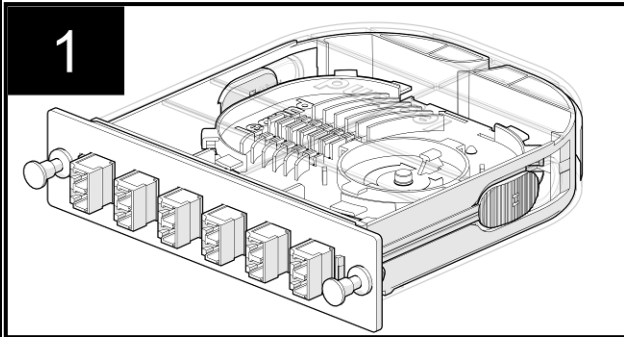
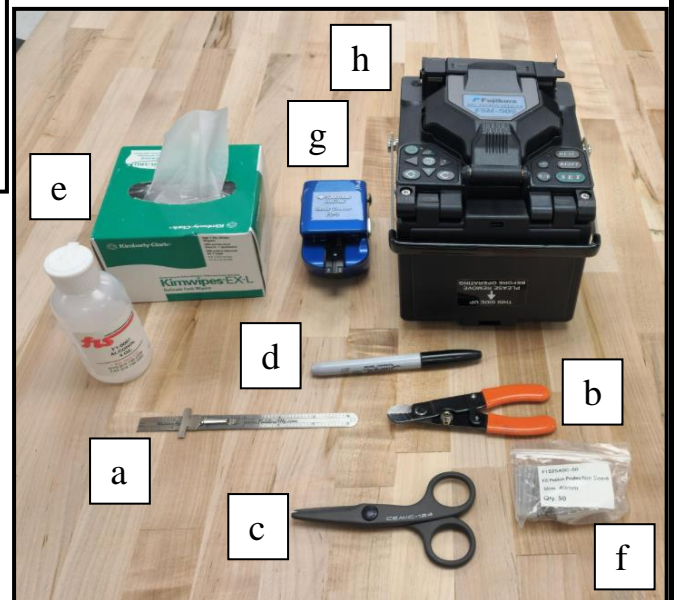

- 3) Prepare to splice: Place the pigtail cassette in a convenient location near your fusion splicer. Make sure both the pigtail and the external cable fibers to which they are to be spliced are set in convenient locations to minimize the need for cable maneuvering. Strip off the outer jacket of the incoming fibers to expose approximately 40 inches of the subunit jacket, remove any exposed aramid yarn (Figure 6). Cut back the subunit jacket to expose about 5 inches of buffered fiber. Install the splice sleeves on the fiber before cleaving the fibers (Figure 7). Prepare the fiber pigtail ends as well (exposing about 5 inches of buffered fiber).

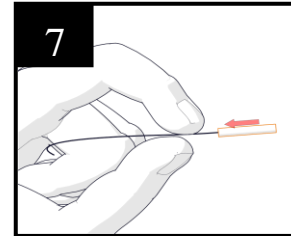
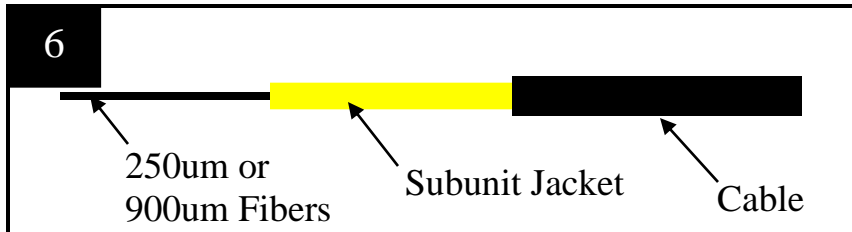

- 4) Splicing: Strip, cleave and splice the fibers, following the instructions associated with your particular fusion splicer (Figure 8), and then slide the protective sleeve over the completed splice (Figure 9). Shrink the protective sleeve onto the fiber and place the finished splice in the appropriate slot on the splice manager (Figure 10). Repeat as necessary. When splicing is complete, you may wish to check for any poor splices using a VFL.

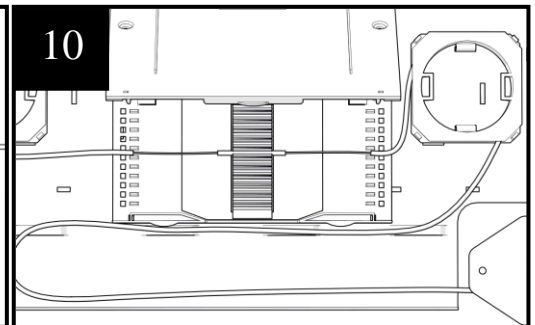
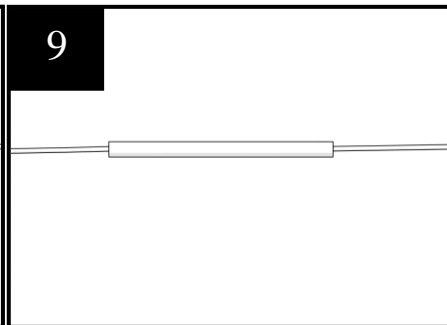
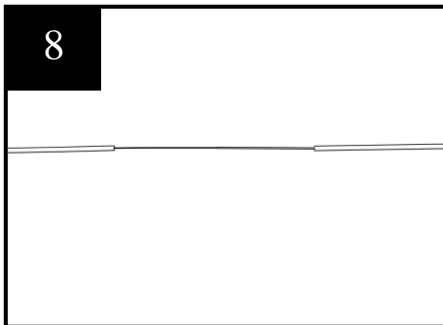

- 5) Cable Management (Figure 11): The suggested enclosure fiber routing is shown below. When using Pigtail Cassettes in an SD or HD enclosure with the FST3-F048 or FST3-A144, shift the splice trays rearward in the enclosure to allow for better bend radius control of the fiber exiting the cassette (Figure 12).
- 6) Mount: Mate the completed cassette from the rear of the enclosure to the correct bezel mounted in the enclosure front. Once the cassette is snapped into place, push the slide locks to the full forward position. Installation is now complete.

