

OCC. SENSORS

WALL CONTROLS

DAYLIGHTING

TOUCHSCREEN & INTERFACES

ROOM NETWORKING

CABLES

WIRED DLM RULES & BEST PRACTICES

DLM INSIDE THE ROOM

- Room Controllers must always be powered with a constant hot (unswitched) circuit.
- Use WS LMRJ-xx Cat 5e cables to ensure reliable communication between devices
- No more than 4 total 100 series load controllers: LMRC-102 / LMPL-101 / LMPB-100 on a DLM Cat 5e Room Network (aka IRB "In Room Bus"). IRBs with only 100 series load controllers have a max of 24 devices and 8 loads. Other DLM RCs and LMCPs have smart power supplies, which allows a max of 64 loads or 48 devices.
- Check total mA consumption of DLM devices against total current available from all LMRCs, LMCPs & LMZCs on the Cat 5e network to a max of 800mA. LMRC-10x / LMPL-100 / LMPB-100 will not limit their 150mA current which is why there's a limit of max 4 units on IRB. Other LMRCs, LMCPs & LMZCs automatically limit their current on Cat 5e room network to ≤ 800mA.
- Don't overload rooms: DLM allows 150' Cat 5e (free topology) per intelligent DLM device, to a max of 1,000' per IRB. Suggest rooms have < 32 loads (and never more than 4 total 100 series RCs) and < 24 DLM devices unless reviewed by Project Management.
- 2 & 3 Relay Room Controllers are for multi-level lighting or multiple zones inside a room, not multiple rooms.
- Rooms ideally should have only one "occupancy state". Multiple occupancy zones in a room are possible, but makes setup more challenging.
- LMLS units require another DLM device (LMCP, OS,...) to turn loads On initially, else set Load to "Auto On" in LMCS.
- Pay attention to all LMRC-22x warnings: 1) Don't share neutrals; 2) Don't mix dimming loads types on LMRC-222s; 3) Every dimming load type should be on separate circuits.

DLM LMCP RELAY PANEL

- Panels are basically large RCs, but DO NOT connect multiple panels with Cat 5e wire - only use Network Bridges.
 - Each LMCP Panel provides 2 separate Cat 5e IRB networks, each allowing max 47 DLM devices. Loads for all relays in panel and in connected RCs remains Max 64.
 - Panels use below equivalency table when connecting to a LMSM (to calculate allowed segment room/device limits):
- | | | |
|----------------|---|----------------------|
| LMZC-301 panel | = | 1 rooms / 10 devices |
| LMCP-8 panel | = | 3 rooms / 20 devices |
| LMCP-24 panel | = | 5 rooms / 30 devices |
| LMCP-48 panel | = | 7 rooms / 40 devices |

**DLM On/Off Demonstration Kit
LMKT-DEMO**

- Prewired DLM kit includes:
- (1) LMRC-102 (w/2 LED Lights)
 - (1) LMSW-102-W, (1) LMPC-100
 - (2) LMRJ-03, (1) LMCT-100-2

Demo kit is great training aid - suggest including on larger projects.

**Ceiling Mounted
LMDC-100
Dual-Tech
Occupancy Sensor**

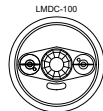

20mA @ 24VDC

**LMUC-100
Ultrasonic
Occupancy Sensor**



20mA @ 24VDC

**LMPC-100
PIR
Occupancy Sensor**

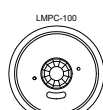

7mA @ 24VDC
LMPC-100 Lens Types
Standard = 360° View
-1 = High Density Lens
-5 = High Bay Lens

**Wall or Corner
Mounted
LMDX-100
Dual-Tech
Occupancy Sensor**



20mA @ 24VDC

**LMPX-100
PIR
Occupancy Sensor**

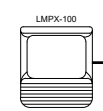

7mA @ 24VDC
LMPX-100 lens types:
Standard = 90° View, 45'
-1 = Long Range Lens
-3 = 2-Sided Aisle Lens
-4 = 1-Sided Aisle Lens

When multiple sensors are in a DLM Room, each can be programmed to control any of the loads in the room.

DLM Switch Buttons can control Loads in a room On/Off, goto a Scene, or control a network group (if room to room network present). DLM Rockers (dimmers) raise/lower Loads in a room.

New! LMSW-2xy Wall Switches and Dimmers

x = # buttons, y = # rockers. Plates not included.
ID color by suffix: Initially -W=White, but soon to follow:
-LA = Light Almond, -I = Ivory, -GRY = Gray, -BK = Black, -RED, and -BR = Brown

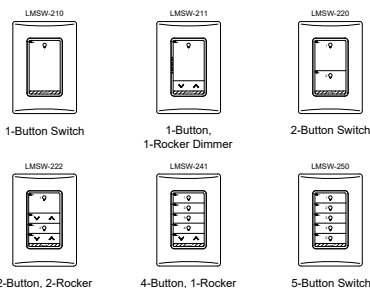

5mA @ 24VDC

New! LMDW-2xy Wall Switch Occupancy Sensors

**LMDW-2xy
Wall Switch Dual-Tech
Occupancy Sensor**

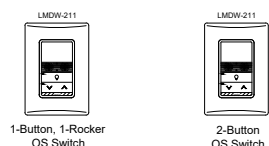

20 mA @ 24VDC

LMSW-10x Wall Switches and Dimmers
x = # buttons and rockers. ID color by suffix: -W=White, -I=Ivory, -LA=Light Almond, -B=Black, -G=Gray, -R=Red.
Pre-Engraved versions are available.

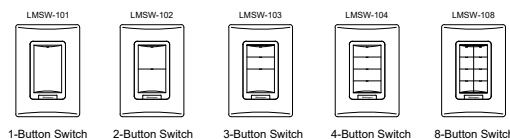

LMDM-101 Dimmer
LMSW-105 Scene Switch



5mA @ 24VDC

Wall Switch Occupancy Sensors

**LMDW-10x Wall Switch Dual-Tech
Occupancy Sensor**
**LMPW-10x Wall Switch PIR
Occupancy Sensor**

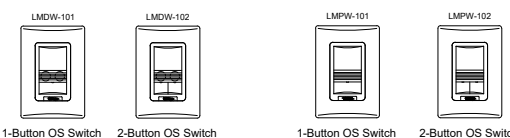

20 mA @ 24VDC 8 mA @ 24VDC

Room Photosensors
Interior sensors for On/Off, BiLevel, Trilevel or Dimming

**LMLS-400(-L)
Daylighting Sensor
Closed Loop**
1 Zone, 1 - 1,553 FC

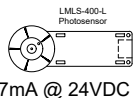

7mA @ 24VDC

**LMLS-500(-L)
Daylighting Sensor
Open Loop**
3 Zone, 1 - 6,553 FC

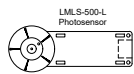

7mA @ 24VDC

LMLS-400/500 fits ceiling tiles 0" - 5/8", -L fits 5/8" - 1 1/4". Zones can be Switching, Bi-Level, Tri-Level or Dimmed (requires dimming LMRC controller). Use LMLS-MB1 for 4 Sq. or 2G J-Box mount, LMLS-MB2 for drywall mount.

**Exterior and Skylight
On/Off Network
Photocells**

Include one LMIN-104 per each LMPO or LMPS photocell. Controls a Network Group of loads based on Light Level.

**LMPO-200
Outdoor Photocell**
0-200 FC

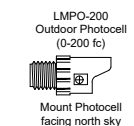

Mount Photocell facing north sky

**LMPS-6000
Skylight Photocell**
0-6000 FC

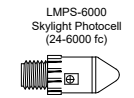

Mount Photocell facing north sky

**New! Touchscreen
RTI-KX4
4" Touchscreen**

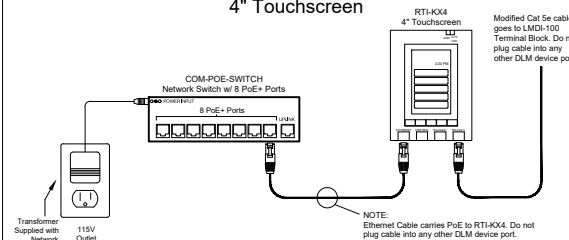

4" Touchscreen with a Room, Lighting, and Shade screen. Requires separately ordered LMDI-100 and COM-POE-SWITCH.

Interface Modules

**LMRL-100
Isolated Relay**

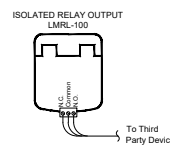

7mA @ 24VDC

Provides occupancy contact for fans, HVAC or Alarms (doesn't count as intelligent DLM device) 24V 1A SPDT Relay 1 NO/NC output terminal

**LMDI-100
RS-232 Interface**

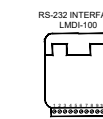

20mA @ 24VDC

Allows bi-directional RS-232 from other products to send DLM room devices commands and/or receive room status.

**LMOR-102
LV Dual Relay Interface**

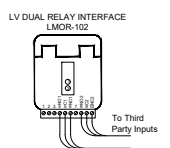

20mA @ 24VDC

Two isolated low voltage mech. held relays can be bound to DLM control devices. Max 1A @ 24V, 2 SPDT Relays with NO/NC output terminals

**LMIN-104
LV 4 Input Interface**

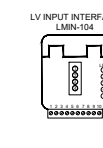

20mA @ 24VDC

Controls loads, scenes, or groups. Replaces LMIO-101, LMIO-102 (Partition), LMIO-201 (Analog OS - requires BZ powerpack), and LMIO-301 (Exterior PC). No other function if Partition or PC.

Partition Wallswitch

**LMPS-104
Partition Switch**

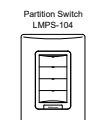

5mA @ 24VDC

LMPS-104 switch allows 16 profiles for up to 4 walls in a DLM Room to be set manually. Use LMIN-104 (replaces LMIO-102 Partition Interface) for 1-4 contact closures.

**LMBC-300
MS/TP Network
Bridge Connector**

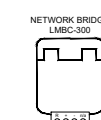

30mA @ 24VDC
Provides BACnet connection (via LM-MSTP wire) to DLM Cat 5e Room Network

**LMBC-650
IPv6 Wireless Network
Bridge Connector**

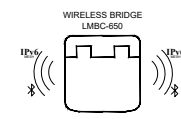

20mA @ 24VDC
Wireless connects DLM room to LMBR-650 Border Router

**LMCT-100-2
Wireless
Configuration Tool**



Include at least 1 LMCT on every project.

LMCS

Software to program, document and upgrade DLM room devices (via LMCI-100 or NB-ROUTER). Available from WS Website (Computer by Others)



**LMCI-100
USB Interface to PC for
LMCS Software**

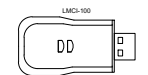

Cat 5e Cables

B-to-B Cat 5e cables in multiple lengths with green jacket. Drop "P" in suffix for non-Plenum, add "-W" after length for White jacket (Plenum rated only).

- LMRJ-01 6"
- LMRJ-03 3'
- LMRJ-10 10'
- LMRJ-P15 15'
- LMRJ-P25 25'
- LMRJ-P35 35'
- LMRJ-P50 50'
- LMRJ-P75 75'
- LMRJ-P100 100'

Cat 5e Accessories

**LMRJ-C8
Coupler**



**LMRJ-S8
Splitter**



**LMRJ-CS8
Plenum Coupler/Splitter**

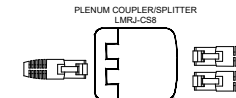

LOAD CONTROLLERS (ROOM and PLUG LOAD)

ON/OFF Room Controllers

LMRC-10x rated 20A, 120/230/240/277VAC, 50/60 Hz, have 3-Cat 5e DLM ports, and provide 150mA @ 24VDC for DLM devices (see 4 max rule for LMRC-10x/LMPB-100/LMPL-101)

LMRC-102 (LMRC-101 not shown) 2-RELAY ON/OFF CONTROLLER Two (2) controllable switch-legs, 20A max

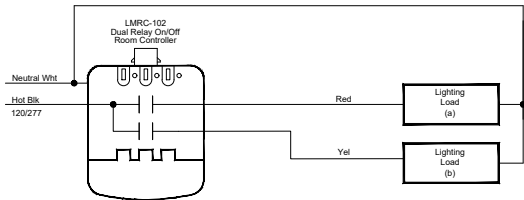

0-10V Dimming Room Controllers

LMRC-21x units are rated for 20A, 120/230/240/277VAC 50/60 Hz input circuit (or 347VAC), have 4-Cat 5e DLM ports, an Input Current Monitor, and intelligently provide 250mA @ 24VDC for DLM Cat 5e devices. Must be mounted on a 4" sq deep box.

LMRC-213 (LMRC-211, LMRC-212, and "-347" versions not shown) 3-RELAY 0-10V DIMMING CONTROLLER Three (3) controllable switch-legs with 0-10V dimming, 20A max

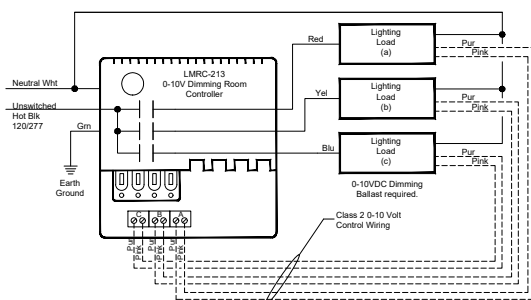

KO Mount 0-10V Dim. Room Controllers

LMRC-11x rated for a 10A or 16A (LMRC-111-16M only), 120/277V 50/60 Hz input circuit, have 2-Cat 5e DLM ports, and intelligently provide 150mA @ 24VDC to power DLM Cat 5e devices. -M suffix indicates Current and Voltage Meter.

LMRC-112-M (LMRC-111, LMRC-111-M, LMRC-111-16M, and LMRC-112 not shown) 2-RELAY 0-10V KO MOUNT DIMMING CONTROLLER Two (2) 0-10V dimming controllable switch-legs, 10A max

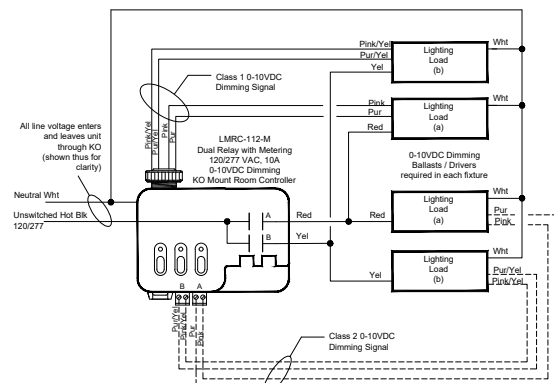

- Notes:
- Class 1 and Class 2 wires can be used individually or together.
 - A "-M" suffix identifies units with an internal Voltage and Current monitoring circuit.

ON/OFF Plug Load Controllers

LMPL-111-20M are UL Listed for Plug Load control and rated for 20A, 120V 60 Hz. They have 2-Cat 5e DLM ports, and intelligently provide 150mA @ 24VDC to power DLM Cat 5e devices (Note LMCP relays are also Plug Load rated). Input circuit metered for Current and Voltage.

LMPL-111-20M PLUG LOAD CONTROLLER WITH METERING 1 Controlled Output, 1 Constant Hot Output

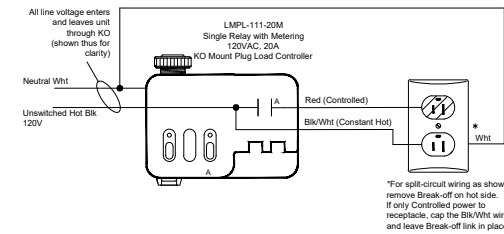

WRC Series (Not a DLM Controller)
WRC-TX-LM Wireless Transmitter and WRC-XX-X Controlled Decorator Receptacles. Transmitter controls max 16 receptacles up to 30' (further with direct line of sight). ID Receptacle color by suffix: -W=White, -I=Ivory, -LA=Light Almond, -B=Black, -G=Gray

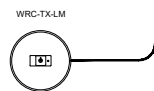

DLM Wireless Transmitter for WRC Controlled Receptacles requires 3mA @ 24VDC



WRC 20A Both Outlets Controlled



WRC 20A Single Outlet Controlled



WRC 15A Both Outlets Controlled



WRC 15A Single Outlet Controlled

Power Booster

LMPB-100 requires a 120/277VAC, 50/60 Hz power, has 3-Cat 5e DLM ports, and provide 150mA @ 24VDC to power DLM Cat 5e devices (see 4 max rule for LMRC-10x/LMPB-100/LMPL-101)

LMPB-100 POWER BOOSTER Does not control any switchlegs

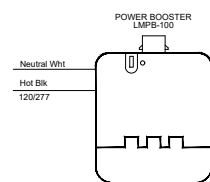

FIXTURE CONTROLLERS

0-10V Dimming Fixture Controller

LMFC-011 rated 3A, 120/277V, 50/60 Hz. Connects via LMFC-xRJ adaptor to DLM room devices. Provides 0mA (zero) @ 24VDC to Cat 5e so LMZC-301 or other Load devices required.

LMFC-011

INDIVIDUAL 0-10V FIXTURE CONTROLLER
One (1) 0-10V dimming controllable switchleg 3A



requires 3mA @ 24VDC

Cat 5e Accessories for Fixture Controls

LMFC-RJ-50-24 1 Port Round Interface

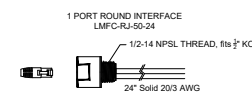

LMFC-2RJ 2 Port Rect Interface

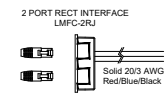

0-10V Dimming Converters

Devices that can use a 0-10V dimming signal to provide a phased dimmed line voltage load output.

BF-SDS10V-AST

Automatically provides a Forward or Reverse Phase line voltage output based on a 0-10V signal. 750W @ 120VAC, 1300W @ 277VAC (24W min.)

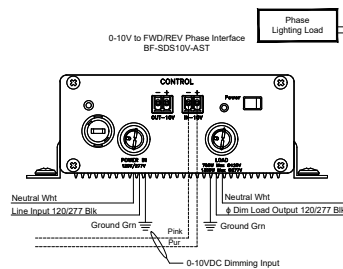

LDCM-PL-120-277-10V-GR

KO mount device automatically provides a Reverse Phase line voltage output based on a 0-10V signal. 1000W @ 277VAC, 450W @ 120VAC.

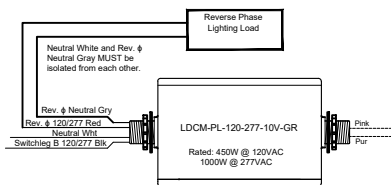

LIGHTING CONTROL PANELS AND ZONE CONTROLLERS

LMCP Panels

LMCPs updated 11/20 to include a 0-10V output per relay, note however that direct wired low voltage switch terminals have been dropped. Older On/Off panels (still with the LV switch terminals) can be ordered by dropping "-10V" from the catalog number

LMCP-8-10V Dimming Relay Panel

LMCP-8-10V units have up to 8 SPST Plug Load rated WattStopper HDR relays. Each HDR rated 20A, 120/277/347V, 50/60 Hz circuit. Panel has 4 Cat 5e DLM ports (via 2 separate networks that each provide 250mA @ 24VDC) to power DLM Cat 5e devices. Panel Enclosure is 15.08" H x 16.5" W x 4.50" D

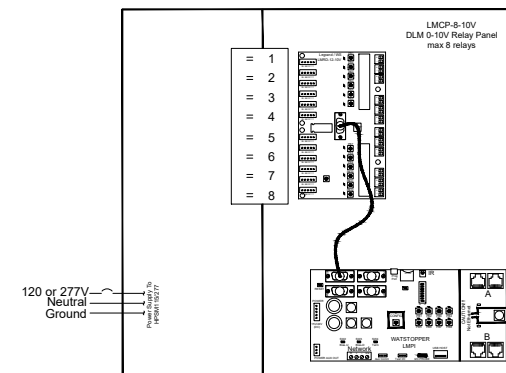

LMCP-24-10V Dimming Relay Panel

LMCP-24-10V units have up to 24 SPST Plug Load rated WattStopper HDR relays. Each HDR rated 20A, 120/277/347V, 50/60 Hz circuit. Panel has 4 Cat 5e DLM ports (via 2 separate networks that each provide 250mA @ 24VDC) to power DLM Cat 5e devices. Panel Enclosure is 31.38" H x 23.88" W x 4.5" D

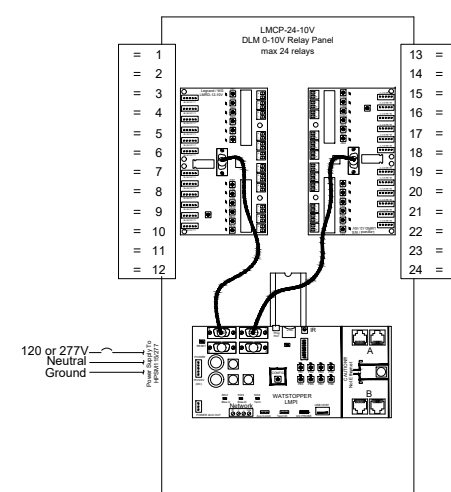

LMCP-48-10V Dimming Relay Panel

LMCP-48-10V units have up to 48 SPST Plug Load rated WattStopper HDR relays. Each HDR rated 20A, 120/277/347V, 50/60 Hz circuit. Panel has 4 Cat 5e DLM ports (via 2 separate networks that each provide 250mA @ 24VDC) to power DLM Cat 5e devices. Panel Enclosure is 43.88" H x 23.88" W x 4.5" D

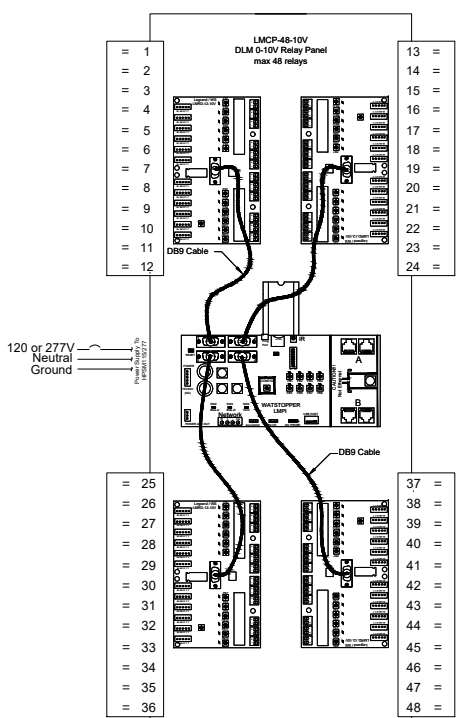

LMCP On/Off Retrofit Kits

Wattstopper offers LMCP Retrofit Kits (On/Off only - no 0-10V) for some older GE, Horton Control, and Wattstopper panels.

LMCP-LI8 LMCP-GE12
LMCP-LI24 LMCP-GE24
LMCP-LI48 LMCP-GE48

LMRJ-WA-5PK

20/4-to-DLM RJ45 converter. Allows existing HDLW-4/-4P wire to older dataline switches to be re-used for DLM Switches in retrofits.



Zone Controller

LMZC-301 enclosure with LMPI intelligence card for 2 separate Cat 5e IRB networks (A&B) to connect to DLM devices needing power (250mA @ 24VDC for A and same for B ports), Time of Day and/or Astro functions. Cabinet is 17.125" W x 10" H x 5.75" D

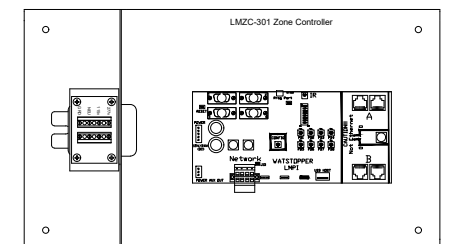

NETWORK ENCLOSURES

WIRED DLM NETWORKING RULES & BEST PRACTICES

DLM NETWORKING (via MS/TP or "Segment Wire")

- **ONLY USE WS LM-MSTP CABLE** for DLM Networking.
- Only one Network Bridge per room. Do not use a single bridge for more than one room, since this makes a large Cat 5e network and leads to difficulties troubleshooting. Only exception to this is with LMCPs and LMZCs since they include Network Bridge on their LMPI intelligence card and may cover multiple rooms.
- Do not run LM-MSTP to multiple floors (except for LMCP panel only runs). Locate LMJA-8xxx or NB-ROUTER at start of all LM-MSTP runs on a wired network project, and ONLY ground shield there. MS/TP wire cannot exceed 4,000' and must be run in daisy chain topology to all rooms/panels. Pay close attention on how LM-MSTP connects to DLM networking devices and where terminating resistors are required (see device installation instructions and TB-179.2).
- WS Networks are as follows with each wired MS/TP segment limited to max 40 Rooms / 340 DLM devices
 - BASIC:** LMJA-8125 controls max 125 Rooms / 2000 DLM devices via 2 LM-MSTP segments (4 total if LMJA-NPB-2X-485 added). Integration via Export Table.
 - ADVANCED:** LMJA-8300 controls max 300 Rooms / 2000 devices via NB-ROUTERS and NB-SWITCH-x. Integration other than via Export Table is Advanced. Advanced requires WS PM review.

DLM WIRELESS NETWORKING (via IPv6 6LoWPAN Wireless Mesh)

- See [Wireless DLM Typical Wiring Detail](#) sheets for complete info on Wattstopper Wireless offering. This sheet only provides detail on using Wired and Wireless Room to Room communication for [Wired DLM Rooms](#).
- Only one LMBC-650 Wireless Network Bridge per room. LMCPs panels cannot communicate via Wireless network, must use MS/TP.
- Wireless DLM Networks are as follows with each LMBR-650 Border Router limited to max 50 REED Devices (in this case Wireless LMBC-650 Bridge), and 250 Total DLM Devices (Bridges + Other Wired DLM Devices). Since these LMBR-650's are located in floor area near devices, their radios are enabled and they are referred to as "Secondary" Border Routers.
- Whenever there is more than 1 Secondary LMBR-650 on a project, a "Primary" Border Router must be added for every group of 10 Secondary units. Primary Border Routers are typically located inside a Small or Large Network Cabinet in an electrical room or IDF Closet and have shall have their radios disabled.
- Primary Border Routers can share same Ethernet Network, but they cannot communicate with each other.
- BACnet info is available from each Secondary Border Router for all the rooms in it's Personal Area Network (PAN). An Export Table of only the desired BACnet variables can be set up via LMCS for the integrator.

Small Network Cabinet

LMNC-ENC1 metal enclosure with surface cover and 2 duplex outlets for networking devices. DIN rail for LMJA-8xxx or Primary LMBR-650 (not Secondary since they use radios). DIN rail on right side for either NB-ROUTER or NB-SWITCH-x. Also room for RACCESS modem. Enclosure is 16" W x 10.5" H x 5.4" D

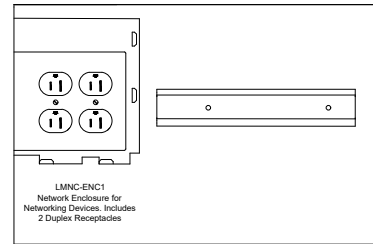

Large Network Cabinet

LMNC-* cabinet with power supply and DIN rails for DLM Network devices. The LMNC is available with no networking devices (-MT), or with 3 to 9 NB-ROUTERS installed and pre-wired to the power supply (-3 to -9). Power supply includes 2 120V outlets for SegMan adaptor and for convenience. LMNC-3 & -4 include NB-SWITCH-8, -5 to -9 units include NB-SWITCH-16. LMSM must be ordered separately. Cabinet is 20" H x 16" W x 8.62" D

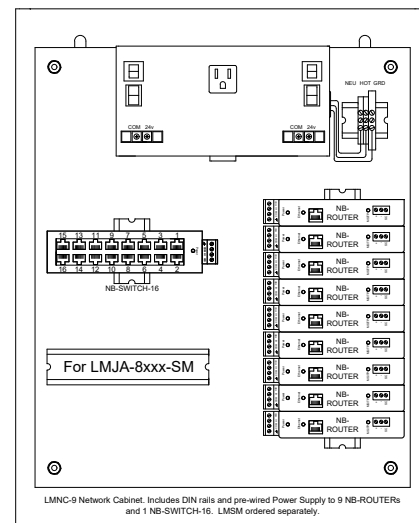

Remote Access Service

RACCESS is a combination hardware, software and cellular solution that can be added to network projects. Cellular modem and 12" magnetic antenna enable remote site communication. Includes services for 1 year.

NETWORKING HARDWARE

Router for Wired DLM Segment Network

NB-ROUTER

BACnet MS/TP to Ethernet Router



Provides routing of BACnet messages from a MS/TP Segment to IP infrastructure.

Border Router for Wireless DLM Network (See Wireless DLM Typical Wiring Detail)

LMBR-650

Wireless Border Router (Opt. Wallwart NB-PS)

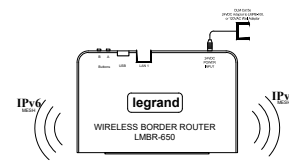

Used in "Secondary" (radio on) or "Primary" mode (aggregator for 2 - 10 Secondary LMBRs). Communicates with IPv6 6LoWPAN Wireless Mesh to Wireless Network Bridges, and relays info to front end devices via Ethernet.

Network Switches for Ethernet

NB-SWITCH(-8, -16)

Ethernet Switches

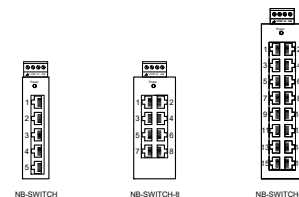

Network Switch provides ports to connect IP devices.
Standard = 5 ports
-8 = 8 ports
-16 = 16 ports

OPTIONAL JACE HARDWARE

LMJA-8xxx

Optional Tridium JACE Network Controller

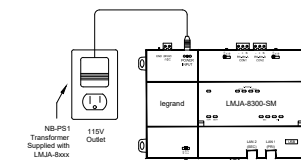

Control, Program and Schedule DLM system. Use to integrate to sites with Tridium Infrastructure, or when color graphics, Fire Alarms, or Custom Programming required. 2 RS485 terminals for MS/TP segments (include LMJA-NPB-2X-485 to add 2 more), or use Ethernet LAN Port and NB-SWITCH-x when project uses NB-ROUTERS or LMBR-650s. Revised in Q2/2021 to include the Segment Manager Station interface on top of latest N4.9 OS. Hardware Versions offered:

LMJA-8125-SM

Wired max: 125 Rooms / 2000 devices
Wireless max: 125 REED / 2000 total wired + wireless devices

LMJA-8300-SM

Wired max 300 Rooms / 2000 devices,
Wireless max 300 REED / 2000 total wired + wireless devices

LMJA-NPB-2X-485

LMJA Add-on module allows for 2 additional MS/TP Segments to be connected to a LMJA-8xxx Network Controller

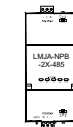

LMJA-IO-R-34

Input/Output Module

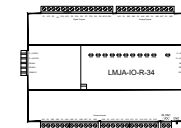

LMJA-IO-R-16

Input/Output Module



LMJA-IO-R-x allow contact closures from other systems to interact with the DLM Network. Note that first unit must be a LMJA-IO-R-34 base device (powered via 24VDC or VAC), and then up to 4 LMJA-IO-R-16 units can be connected directly to it. IO units often used for a fire alarm input to force lights on in DLM system.

MS/TP SEGMENT WIRING

MS/TP Segment Cable & Harness

WS plenum-rated 22/3 shielded wire is required for DLM segment networks. LM-MSTP has green jacket, add -B for Black, -W for White, and -DB for Direct Burial Black. Order by foot, or LM-MSTP available in 1,000', 2,000', or 4,000' reels (use suffix -S1000, -S2000, or -S4000)

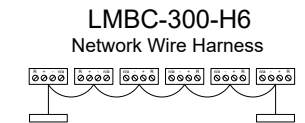
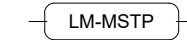

SHADE CONTROLLERS AND MOTORS

DLM SHADE RULES & BEST PRACTICES

DLM SHADES INSIDE THE ROOM

- Always ensure Shade Controllers are fed with a constant hot (unswitched) circuit.
 - Use WS LMRJ-xx Cat 5e and LMSH-SBCA-Pxx Shade Bus cables to ensure reliable communication between devices.
 - There are two separate buses in the DLM Shade system - one is the same Cat 5e In Room Bus (IRB) used in Wired DLM Lighting products to provide 24VDC power to DLM Shade Switches and communication between controllers and switches. The second bus is the "Shade Bus", a 4-wire conductor providing DLM communication and power (24VDC from LMSH-PS602, 36VDC from -PS610) to Shade Motors. Note that Shade Buses from different controllers should never be intermingled - motors should be powered by and communicate with just a single Shade Controller. Communication between the IRB and the Shade Bus is routed together inside the Shade Controller (similar to a DLM LMZC-301 Panel's A and B networks). Other than the originating Shade Controller, the only devices on the Shade Bus are Shade Motors with each controlling an individual motorized shade load.
 - DLM LMSH-PS6xx Shade Controllers have smart power supplies to power either 2 (-PS602) or 10 (-PS610) motors on the Shade Bus. Each room is limited to 48 devices on the IRB (Shade Controllers + Shade Switches + all DLM Lighting Control devices). Each Controller's Shade Bus is limited based on its model to either 2 Motors or 10 Motors. The total number of loads on all Shade Buses in a room is only limited by the max 64 DLM Load Limit (which applies to Shade Motors + all DLM Lighting Loads).
- (Note: "Banding" is allowed for some of the Wattstopper Shade products - meaning mechanical couplers can be added to connect a motorized shade to one or more non-motorized shades. Non-motorized shades do not count toward the max 64 DLM Load Limit per room.)**
- Shade Bus cables and Shade Bus Extenders DO NOT count toward to load limits or device limits since they are not intelligent DLM products.
 - In a room of DLM Shades, the IRB bus allows multiple Shade Controllers to communicate with each other and to shade switches. Max IRB distances follow Wired DLM IRB Rules - 150' Cat 5e (free topology but no loops) per intelligent DLM device, to a max of 1,000' per IRB. Check total mA consumption of DLM Cat 5e accessory devices on the IRB network against total current available from all Shade Controllers. 24VDC IRB mA from different Shade Controllers is additive but limited to max 800mA by the Shade Controller's smart power supplies.
 - Each Shade Controller provides power for Shade motors up to 500' distance per Shade Bus port (1 port for LMSH-PS602, 2 -PS610). Do not intermingle Shade Bus cables from different Shade Controllers or Shade Bus ports.
 - Shade Motors will be assigned load numbers based on their DLM Serial # (highest is first), similar to Wired DLM devices. In a room with DLM Lighting and DLM Shades, the lighting loads will get the initial load numbers starting with "1", followed by the Shade Motors.
 - Ideally Shade Controllers are for multiple shades inside a single room, not multiple rooms. This is primarily to avoid later confusion by facility personnel. As with Wired DLM lighting products, Rooms should be connected to each other only using a Wired or Wireless Bridge.

LMSH-PS610

Shade Controller and power supply for 1 to 10 motors

LMSH-PS610 accepts either 120 or 277VAC input voltage and mounts on a 4" sq or 4 1/16" junction box. Unit has 2 Cat 5e DLM ports for connection to switches, and 2 Shade Bus ports to connect to motors. LMSH-PS610 intelligently provides 150mA @ 24VDC on IRB for DLM switches. Also provides 1.5A of 36VDC power on Shade Bus for Shade Motors.

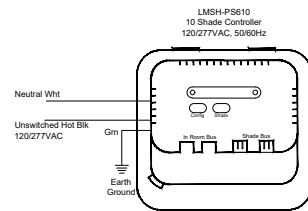

LMSH-PS602

KO Mount Shade Controller and power supply for 1 or 2 motors

LMSH-PS602 accepts either 120 or 277VAC input voltage. Unit has 2 Cat 5e DLM ports for connection to switches, and 1 Shade Bus port to connect to motor units. LMSH-PS602 intelligently provides 150mA @ 24VDC on IRB for DLM devices. Also provides 0.5A @ 24VDC power on Shade Bus for Shade Motors.

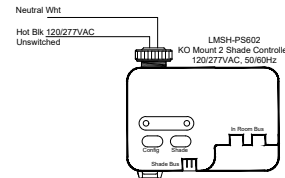

LMSH-MCAxxx Shade Motor

Low voltage motor powered via the Shade Bus cable, each Shade Motor counts as a single load in a DLM room. Connects to Shade Bus via a 13" whip with a female connector. Ships with a LMSH-SBCA-008 8" male-to-male cable to simplify connection to LMSH-SBE4's female ports. Motor has integral Wireless DLM radio, to allow it's firmware to be updated via Wireless DLM Config App.

Available in two different gear ratios:
40:1 smaller and medium shade assemblies
73:1 larger shade assemblies
Specific gear size will be determined by Shade Team Application Engineers based on Dealer provided information.

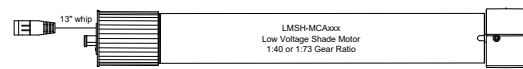

SWITCHES AND REMOTE

See installation instructions for all Shade Switch operations, but generally users can either tap on a load button or rocker to send to send controlled shades to upper or lower level (and if desired can tap on that button again while shade is moving to stop it), or for load buttons they can press and hold button to start moving and let go when at proper level. LMSH-SW102 and -SW104 will automatically assign sheer shades to button(s) with "1" and room darkening to button(s) with "2", although they also have separate PnG behavior if only 1 type of shade is in a room. Buttons on a LMSH-SW105 and LMSH-SW241 have default goto levels of 80%, 60%, 40%, and 20%. All switches consume 5mA @ 24VDC on IRB

New! LMSH-SW2xy Shade Switches

x = # buttons, y = # rockers. Plates not included. ID color by suffix: Initially -W=White, but soon to follow: LA = Light Almond, I = Ivory, GRY = Gray, BK = Black, RED, and BR = Brown

LMSH-SW211 1-Button, 1-Rocker Shade Switch
LMSH-SW222 2-Button, 2-Rocker Shade Switch
LMSH-SW241 4-Button, 1-Rocker Shade Goto Switch

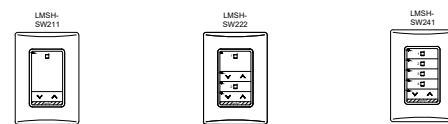

LMSH-SW10x Shade Switches

Plates not included. ID color by suffix: -W=White, -I=Ivory, -LA=Light Almond, -B=Black, -G=Gray, -R=Red

LMSH-SW101 1-Rocker Shade Switch
LMSH-SW102 2-Button Shade Switch



LMSH-SW104 4-Button Shade Switch
LMSH-SW105 1-Rocker, 4-Button Shade Goto Switch



LMSH-CR

Shade Configuration Remote

Handheld configuration remote communicates to shades via LMSH-SWxxx IR Windows. Allows shade limits and other parameters to be easily set.



ACCESSORIES

LMSH-SBE4

Shade Bus Extender

Coupler/Splitter for Shade Bus cables. Provides 4 female Shade Bus terminals to allow a single Shade Bus cable from a Shade Controller to be split to 3 Shade Motors, or 2 Shade Motors and a cable to another Shade Bus Extender for easy wiring of an entire room.

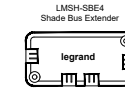

LMSH-SBTEST

Shade Bus Tester

Tester for manually terminated Shade Bus cables. Has a single Shade Bus terminal to verify communication and power is available. Proper cable termination can be verified when both Blue and Green LEDs are lit.

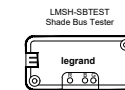

LMSH-SBCA-S2

Shade Bus "Y" Splitter Cable

Ideally used to split a single Shade Bus cable to two different Shade Motors. Splitter has a single female connector (connects to Shade Bus cable), and two separate 6" cables each with a male connector (connects to motors).

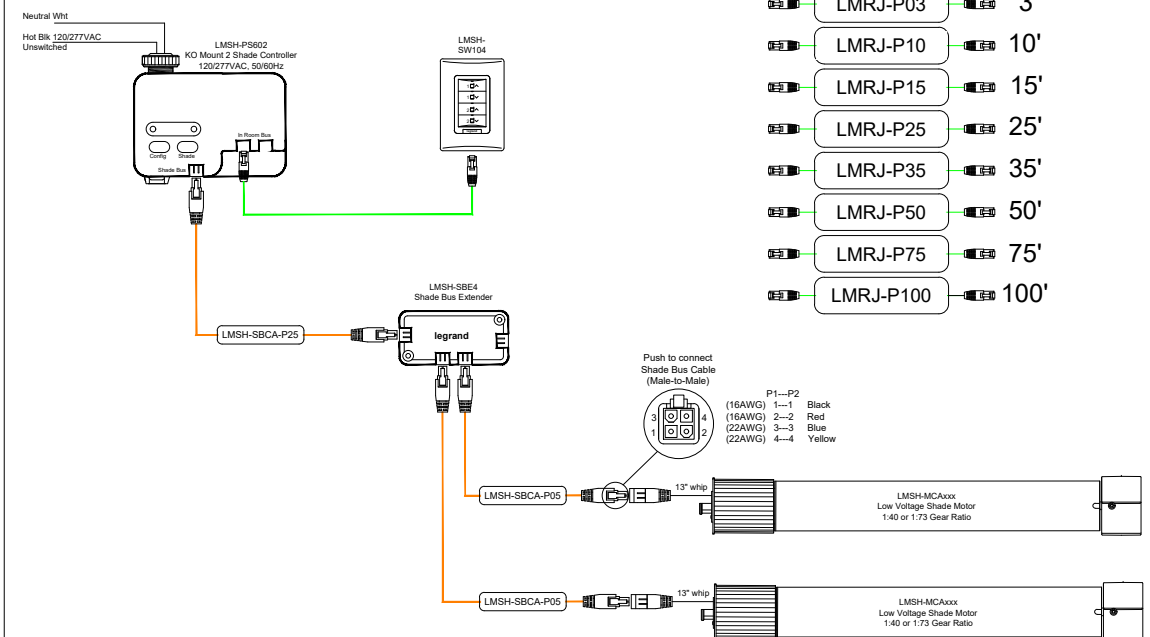
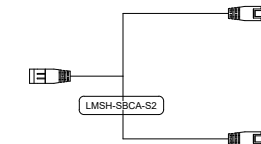

SHADE BUS CABLES

LMSH-SBCA-Pxx

Shade Bus Cables

White male-to-male plenum rated Shade Bus cables in multiple lengths. Cables include 2 wire pairs - one 16 AWG for 24/36VDC power, and one 22 AWG for 24VDC communication. Place below tag on wire to indicate desired length.

Shade Bus cable also available in 1,000' or 2,000' reels via LMSH-SBW-S1000 or LMSH-SBW-S2000. Packages with terminals that make up to 10 cables are available via LMSH-SBWC10. Use Crimp Tool LMSH-SBWCTOOL.

LMSH-SBCA-P008	8"
LMSH-SBCA-P03	3'
LMSH-SBCA-P05	5'
LMSH-SBCA-P10	10'
LMSH-SBCA-P15	15'
LMSH-SBCA-P25	25'
LMSH-SBCA-P35	35'
LMSH-SBCA-P50	50'
LMSH-SBCA-P75	75'
LMSH-SBCA-P100	100'

LMRJ-xxx

Cat 5e Cables

Standard DLM B-to-B Cat 5e cables in multiple lengths with green jacket. Drop "P" in suffix for non-Plenum, add "-W" after length for White jacket (Plenum rated only).

LMRJ-01	6"
LMRJ-P03	3'
LMRJ-P10	10'
LMRJ-P15	15'
LMRJ-P25	25'
LMRJ-P35	35'
LMRJ-P50	50'
LMRJ-P75	75'
LMRJ-P100	100'