

0-10V CONTINUOUS DIMMING PIR OUTDOOR PHOTO/MOTION SENSOR IN IP66 ENCLOSURE WITH BLUETOOTH®

FSP-3X1B SERIES



FSP-3x1B

w/ Straight Nipple

w/ Drop Nipple



PRODUCT OVERVIEW

The FSP-3x1B is a family of passive infrared (PIR) outdoor sensors that raise or lower the electric lighting level to appropriate light levels based on motion and/or daylight contribution. Typically, once the sensor stops detecting movement and the time delay elapses, lights will first fade to appropriate light level based on ambient light conditions, and eventually switch off. When motion is detected, the sensor ramps the light level to high mode unless the daylight contribution is sufficient.

The integral photocell can also switch the lights on and off for dusk to dawn control, so that lighting remains on overnight even without motion detection.

The sensors control 0-10VDC or

non-dimming LED drivers or ballasts. The low voltage FSP-301B may be used with dim-to-off drivers or ballasts.

Initial setup and subsequent sensor adjustments are made using the Sensor Configuration App, available on Google® or the Apple® App Store. This tool enables adjustment of sensor parameters including high/low mode, sensitivity, time delay, cut off and more.

The Sensor Configuration App can read current parameter settings, and stores up to six sensor parameter profiles to speed commissioning of multiple sensors.

The FSP-3x1B family is available in three configurations for mounting inside a fixture, to the outside of a fixture or enclosure via a 1/2" knockout, or to a pole.

FSP-3x1B sensor module

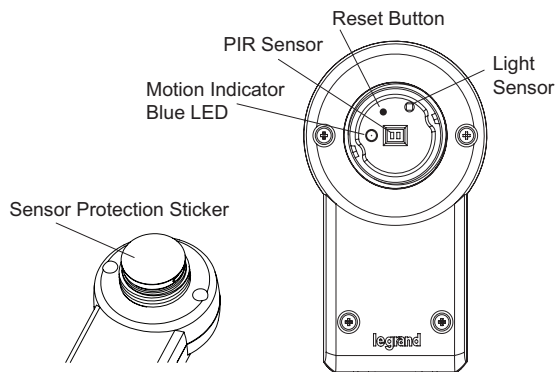

NOTE: Remove Sticker before use

MODELS

FSP-301B, 12–32VDC: Use with dim-to-off driver or ballast or with Wattstopper power pack

FSP-311B, 120–277VAC (single phase), 50/60Hz

FSP-321B, 100–347VAC (single phase)
or 208/230/480VAC (phase-to-phase)

SPECIFICATIONS & FEATURES

Load Ratings (FSP-311B, FSP-321B):
 @ 120V 0–800W tungsten, ballast, LED driver;
 @ 230–240V 0–300W ballast, LED driver;
 @ 277V 0–1200W ballast, LED driver;
 @ 347V 0–1200W ballast, LED driver
 (FSP-321B only)
 @ 480V 0–1200W ballast, (FSP-321B only)

Wiring: FSP-301B – 20AWG,
 FSP-311B and FSP-321B – 18AWG
Lead Length: 12" (30.5cm), 10" (25.4cm) for
 FSP3x1B-D models

Current consumption (FSP-301B): 15 mA max.

0–10V sinking current: 50mA

Three interchangeable lenses for mounting
 between 8' and 40'

Remote setup and adjustment via the iOS®
 or Android® Sensor Configuration App

Adjustable high and low modes
 (high: 0 to 10V, low: off, 0 to 9.8V)

Adjustable time delay (30 seconds, 1 to 30
 minutes)

Adjustable cut off delay (none, 1 to 59 minutes,
 1 to 5 hours)

Adjustable sensitivity/service mode
 (low, med, max; on-fix, off-fix)

Adjustable setpoints: hold off setpoint (none, 1
 to 250 fc, auto); photocell on/off setpoint (1 to
 250 fc)

Adjustable ramp and fade times (1 to 60
 seconds)

Operating temperature:
 FSP-301B: -40°F to +167°F (-40°C to +75°C)
 FSP-311B/FSP-321B: -40°F to +140°F (-40°C to
 +60°C)

Weight: FSP-301B, 4.9oz (140g);
 FSP-311B & FSP-321B, 6.7oz (190g)

UL and cUL listed (E101196)

IP66 rated

Five year warranty

MATERIALS

Polycarbonate, flame retardant, UV resistant,
 impact resistant, recyclable
 Meets materials restrictions of RoHS

FSP-3X1B DIMENSIONS

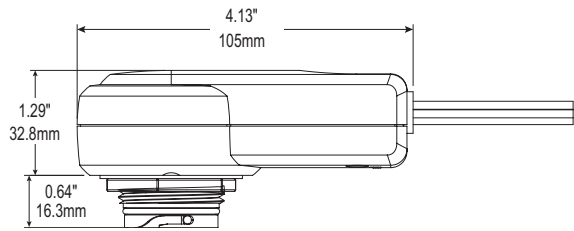

FSP-3x1B

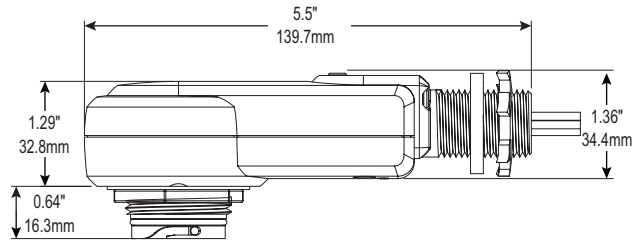

FSP-3x1B-S

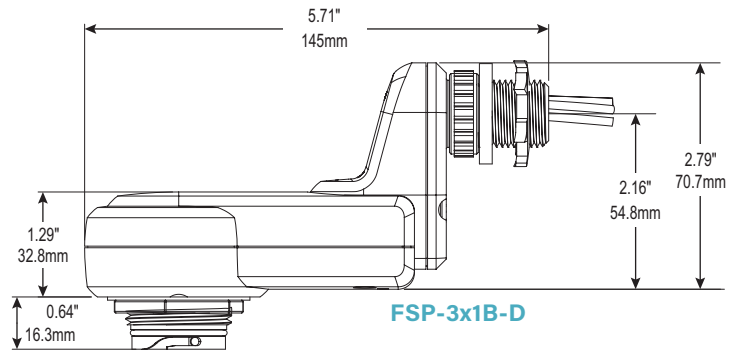
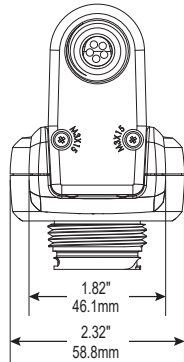
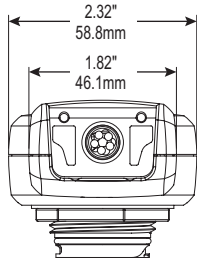

FSP-3x1B-D

COVERAGE

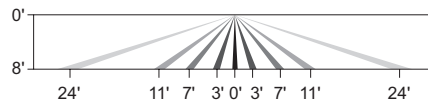
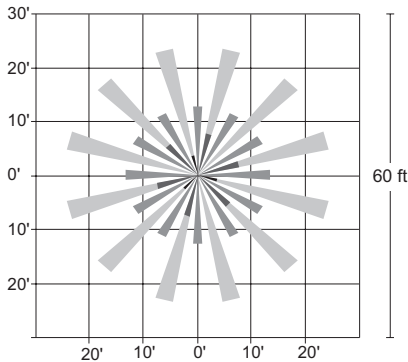

FSP-L2 top and side coverage patterns

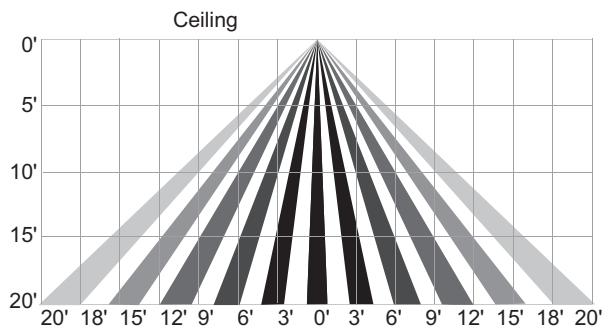
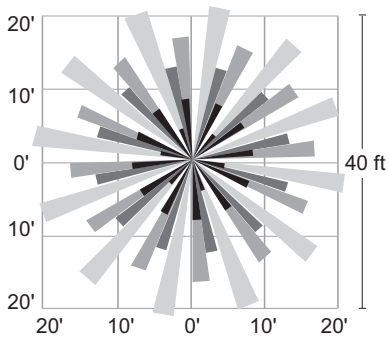

FSP-L3 top and side coverage patterns

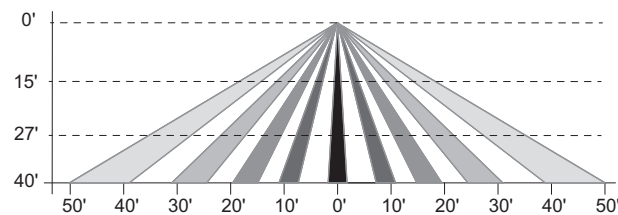
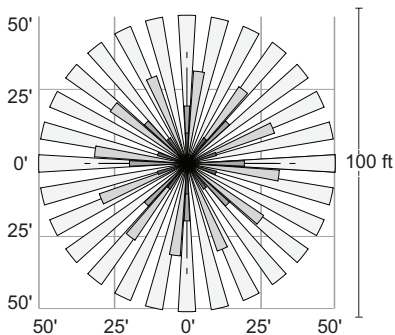

FSP-L7 top and side coverage patterns

DIMENSIONS OF LENS OPTIONS

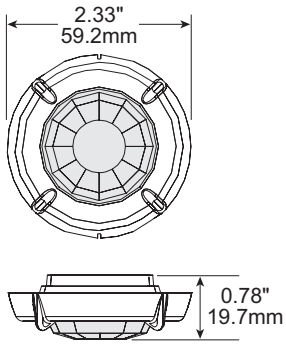

FSP-L2 dimensions

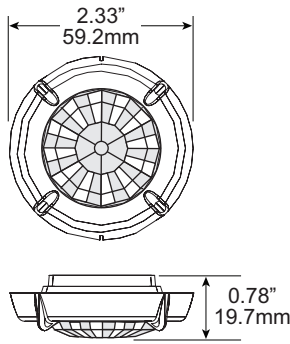

FSP-L3 dimensions

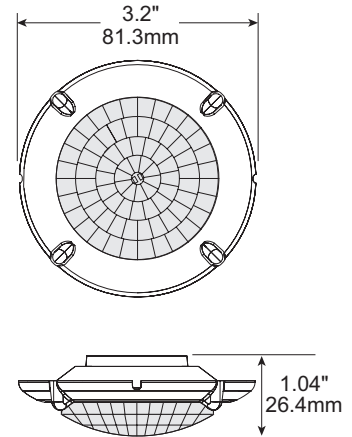

FSP-L7 dimensions

FSP-L2-S, FSP-L3-S, and FSP-L7-S Dimensions

The FSP-Lx-S models include a shroud, which blocks high-angle light coming from the fixture, to improve photocell performance. With the shroud attached, the dimensions for all three lenses are identical

FSP-L2-S and FSP-L3-S

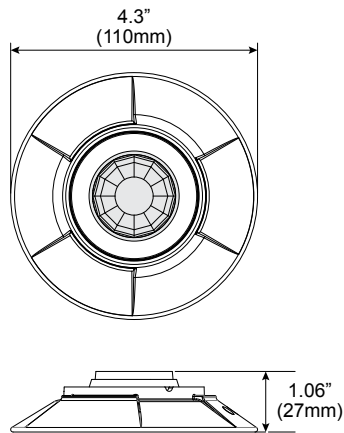

FSP-L7-S

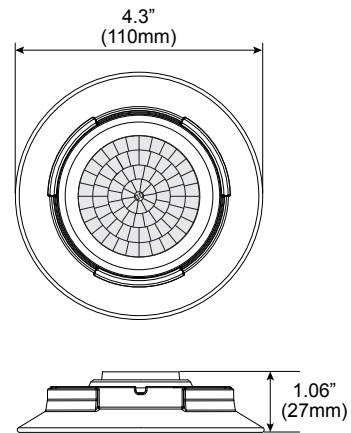

INSTALLING THE FSP-3X1B SENSOR IN LIGHT FIXTURE

- Determine an appropriate mounting location inside the light fixture. Allow a minimum distance of 0.2" (5.1mm) from the end of the sensor to the wall of the fixture.
NOTE: The outside fixture wall thickness should be no greater than 0.125" (3.18mm) for optimal sensor mounting and security.
- Drill a 1.31" (33.3mm) diameter hole through the sheet metal in the bottom of the fixture.
- Place the rubber gasket on the threaded collar, and install the sensor face down, parallel to the mounting surface. Ensure the rubber gasket touches the inside surface of the fixture. Install the tightening nut securely against the fixture and torque to 25-30 in-lbs to maintain IP rating.
- Align the locking features between the sensor and lens module and push the lens module forward until the O-ring seals firmly. Turn the lens module clockwise to lock in place.
- Connect load, supply and control wires

- Restore power from the circuit breaker.

NOTE: An optional collar can be installed in place of the tightening nut on the FSP-3x1

NOTE: An optional shroud with integrated lens can be installed instead of the collar and a regular lens. The shroud blocks high-angle light coming from the fixture, to improve photocell performance.

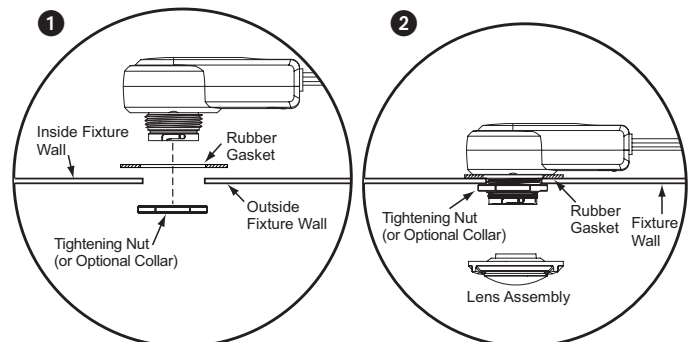

INSTALLING THE FSP-3X1B-S OR FSP-3X1B-D TO A FIXTURE OR POLE

1. Determine an appropriate mounting location minimizing the electrical light contribution to the sensor's photocell.
2. Drill a 0.875" (22mm) diameter hole through the mounting surface, or mount to a 1/2" knockout.
3. Place the rubber gasket on the threaded collar, and install the sensor face down, parallel to the mounting surface. Ensure the rubber gasket touches the mounting surface. If needed, add the spacer between the sensor body and the rubber gasket to ensure a secure fit. Install the nipple nut and torque to 25-30 in-lbs to maintain IP rating.
4. Align the locking features between the sensor and lens module and push the lens module forward until the O-ring seals firmly. Turn the lens module clockwise to lock in place.
5. Connect wires (see wiring diagrams).
6. Restore power from the circuit breaker.

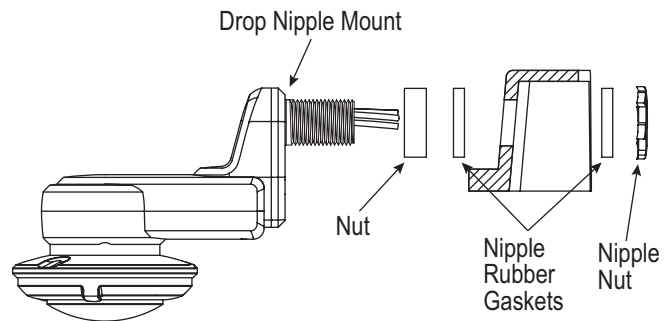
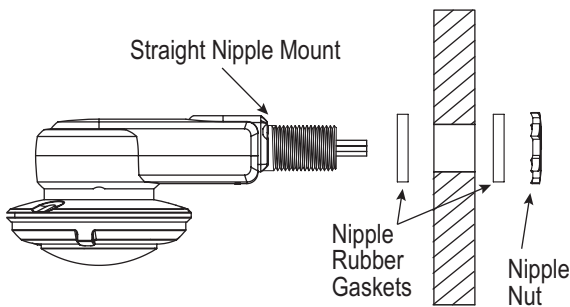

Installing the FSP-3x1B-S to the exterior of a fixture

NOTE: The outside fixture wall thickness should be no greater than 0.125" (3.18mm) for optimal sensor mounting and security.

Installing the FSP-3x1B-D to a pole using the optional spacer

NOTE: The outside fixture wall thickness should be no greater than 0.125" (3.18mm) for optimal sensor mounting and security.

WIRING DIAGRAMS FOR LOW VOLTAGE FSP-301B SENSORS

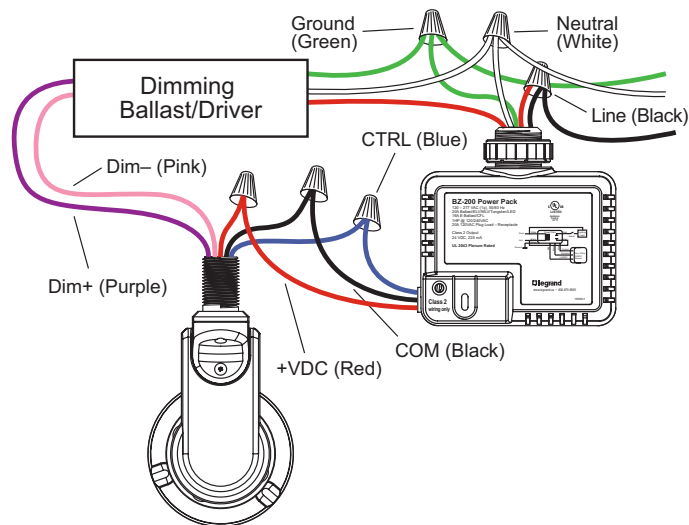
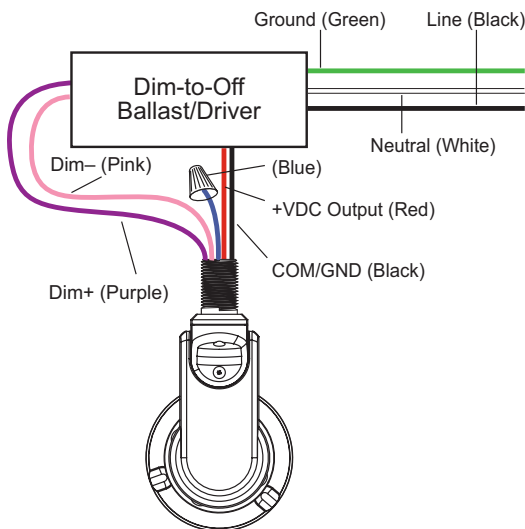

FSP-301B wiring with dim-to-off ballast or LED driver

FSP-301B wiring with dimming ballast or LED driver and power pack for on/off control. If using a non-dimming ballast/driver, simply cap the pink and purple leads

NOTE: Per UL, the 0-10V negative dimming wire color has been changed from gray to pink.

WIRING DIAGRAMS FOR LINE VOLTAGE FSP-311B AND FSP-321B SENSORS

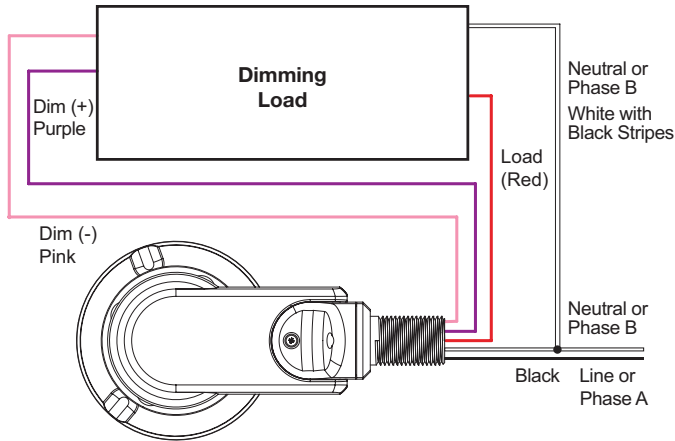

FSP-3x1-B wiring with dimming ballast or LED driver

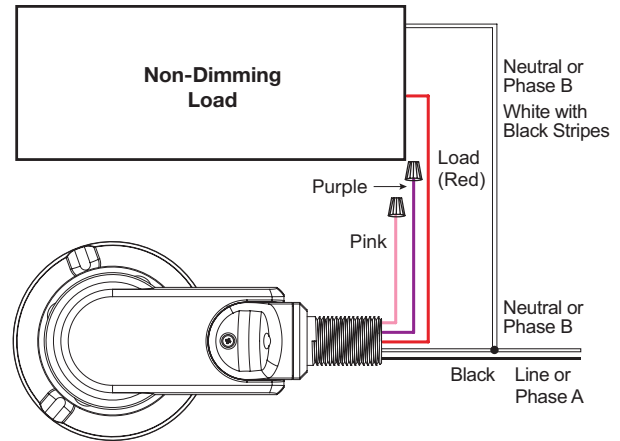

FSP-3x1-B wiring with non-dimming load

NOTE: Per UL, the 0-10V negative dimming wire color has been changed from gray to pink.

SEQUENCE OF OPERATION

- Dimming:** When motion is detected within the sensor's coverage area, the sensor sends a signal to ramp the load up to the selectable High Mode level unless the ambient light level is higher than the selected setpoint. When no motion is detected for the duration of the time delay setting (factory preset at 5 minutes), the lights will go to the selectable Low Mode level based on the signal from the sensor. If desired, a cut off time delay (factory preset at 1 hour) will trigger to eventually turn the lights OFF.
- Non dimming:** When motion is detected within the sensor's coverage area, the sensor sends a signal to turn the load ON unless the ambient light level is higher than the selected setpoint. When no motion is detected for the duration of the time delay setting (factory preset at 5 minutes), the lights will go OFF based on the signal from the sensor.
- Dusk to dawn control:** When photocell on/off is enabled, and the ambient light falls below the photocell setpoint, the sensor ramps the load up to the selectable High Mode level. If no motion is detected for the duration of the time delay setting (factory preset at 5 minutes), the lights will go to the selectable Low Mode level. If the cut off time delay is disabled, the load will remain on, at High or Low level, based on motion detection, until the ambient light increases above the photocell setpoint.
- Continuous Dimming:** The sensor continuously adjusts the light level of the load based on the changing ambient light level and whether the area is occupied or not. The sensor can set separate desired light levels for day and night.

ADJUSTABLE CONTROL PARAMETERS

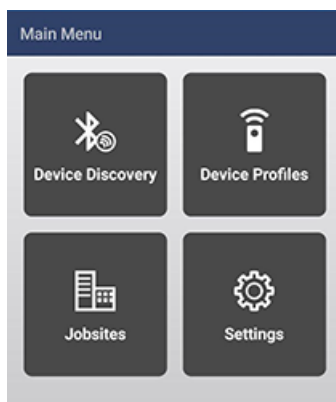

The Sensor Configuration App is a convenient tool for setting up FSP-3x1B sensors. Adjustable settings can be changed as needed for specific applications.



Maximum recommended distance between mobile device running Sensor Configuration App and the sensor: 50 ft.

Bluetooth communication ranges can vary depending on the device, as well as mobile carrier. Wattstopper recommends devices with Bluetooth 5.0. Iphone 8 and Samsung Galaxy S8 and later devices are recommended for optimal performance.

Fixed Mode Parameters

- High Mode:** When the sensor detects motion the dimming control output ramps up to the selected HIGH light level (default is 10V).
- Low Mode:** After the sensor stops detecting motion and the time delay expires the dimming control output fades down to the selected LOW light level (default is 1V).
- Time Delay:** The selected time period that must elapse after the last time the sensor detects motion for the electric lights to fade to LOW mode (default is 5 minutes).
- Cut Off:** The time period that must elapse after the lights fade to LOW mode and the sensor detects no motion for the electric lights to turn OFF (default is 1 hour). If disabled, there is no cut off, the lights will stay in low mode.
- Sensitivity:** The response of the PIR detector to motion within the sensor's coverage area (default is High).
- Hold Off:** The selectable ambient light level threshold that will hold the lights off or at LOW level when the sensor detects motion (default is Disabled). A switch allows you to Enable or Disable this feature. If enabled, select Auto Format or Custom Value. If Custom is selected, the Range is 1 fc to 250 fc.

The Auto option invokes an automatic calibration procedure to establish an appropriate setpoint based upon the contribution of the electric light. As part of this procedure, the controlled load is turned on for two minutes to warm up the lamp, and then switched off and on eight times, terminating in an off state. After this process, a new setpoint value is automatically calculated.

- Ramp Up Time:** Time period for light level to increase from LOW to HIGH (default is Disabled; lights switch instantly).
- Fade Down Time:** Time period for light level to decrease from HIGH to LOW (default is Disabled; lights switch instantly).
- Photocell On/Off:** When enabled, the sensor will force the load OFF after the light level has exceeded the selected photocell setpoint for at least a minute. It will also force the load ON when the light level goes below the setpoint, even if no motion is detected (default is Disabled).

Once ON (initially at High), the load will dim to Low following the Time Delay, and to OFF following the Cut Off time. To ensure dusk to dawn control, Cut Off must be disabled.

The photocell On/Off setpoint is automatically set to maintain a deadband of at least 10 fc above the Hold Off Setpoint to prevent cycling if the two features are used together.

Continuous Dimming Mode Parameters

If Continuous Dimming is enabled, the fixed parameters are replaced by Continuous Dimming parameters. There are two sets of parameters—one for day and one for night.

Occupied Target: During the day/night, and while the area is occupied, the sensor will attempt to maintain the light level specified. The range is 0-250 fc (default is 30 fc).

Occupied Time Delay: The time period that must elapse after the last time the sensor detects motions before the lights to fade to the specified 'Unoccupied Target' or 'Unoccupied Fixed Level' (default is 5 min).

Unoccupied Target: During the day/night, and while the area is unoccupied, the sensor will attempt to maintain the light level specified. The range is 0-250 fc (default is 30 fc). The Fixed 0-10V Level may be used instead.

Unoccupied Cut Off: The time period that must elapse after the last time the sensor detects motion before the lights to fade to Day/Night Unoccupied Target (default is 5 min).

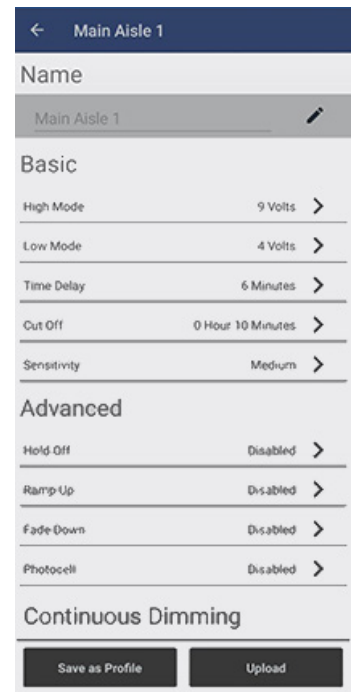

FACTORY DEFAULTS	
High mode:	10V
Low mode:	1V
Time delay:	5 minutes
Cut off:	1 hour
Sensitivity:	Max
Ramp up time:	Disabled
Fade down time:	Disabled
Photocell On/Off:	Disabled

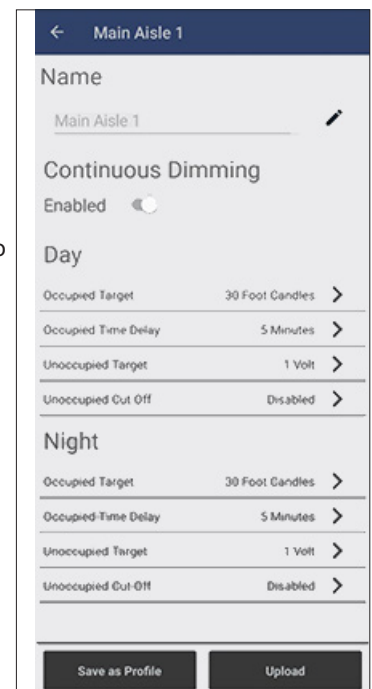

TESTING THE FSP-3X1 WITH THE SENSOR CONFIG APP

1. The first time the sensor is installed and powered, there will be 50 seconds of warm-up. The load will turn OFF after the warm-up time if no motion is detected. To test functionality further, proceed to steps below
2. Log in to the Sensor Config App, then tap **Device Discovery**. The **Devices** screen opens and displays a list of sensors along with their signal strength.
3. Tap a sensor. The loads connected to that sensor will flash ON and OFF, to give a visual indication of which sensor you are communicating with. After a few seconds, the **Device Security** screen opens.
4. Turn the **Select Jobsite** switch Off. This allows you to test the sensor without having to store a password in the sensor. Then tap **Submit**.
5. Tap the **Controls** option. The parameters on this page are used for testing the sensor. Additionally, the current amount of light registered by the light level sensor, as well as the sensor's firmware version is displayed.
6. Tap **Test Mode**. This mode shortens timeouts for High/Low and Cut Off, to allow quick verification of settings. You can set the length for test mode (default is 3 minutes). Range: 1 to 5 minutes. Tap Start to enter test mode.
7. If you tap **Dimmer Level**, the screen shows the current dimming level (from 0V to 10V). You can temporarily change the dimming level for testing purposes by dragging the slider or tapping the "+" or "-" buttons. The level will change to the specified amount for several seconds, then revert to the previous amount.

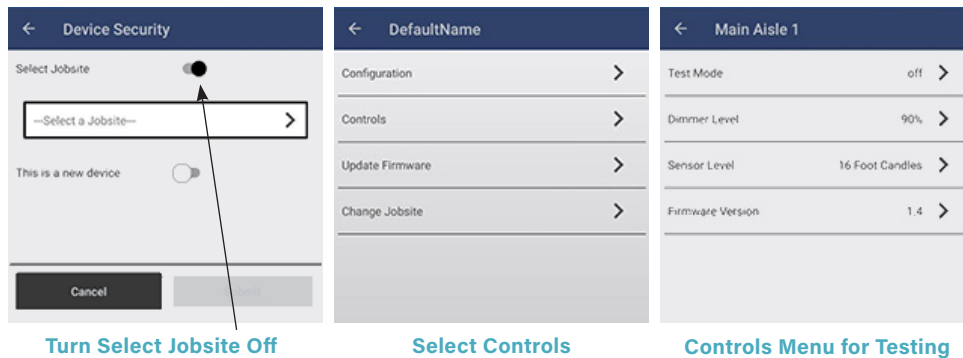

ORDERING INFORMATION

Catalog #	Master Pack Details					Inner Pack Details				
	Master Pack Quantity	Case dimensions (inches)			Weight (pounds)	Inner Pack Quantity	Case dimensions (inches)			Weight (pounds)
		Length	Width	Height			Length	Width	Height	
FSP-301B	40	19.25	12.7	11.7	21.9	20	18.8	12.3	5.3	9.85
FSP-301B-S-L2/L3	40	22.2	15.9	16.1	26.6	20	21.7	15.4	7.6	12.2
FSP-301B-S-L7	40	22.2	15.9	16.1	28.7	20	21.7	15.4	7.6	13.2
FSP-301B-D-L2/L3	40	22.2	15.9	16.1	28.6	20	21.7	15.4	7.6	13.2
FSP-301B-D-L7	40	22.2	15.9	16.1	30.7	20	21.7	15.4	7.6	14.2
FSP-311B	40	19.25	12.7	11.7	26	20	18.8	12.3	5.3	11.9
FSP-311B-S-L2/L3	40	22.2	15.9	16.1	30.7	20	21.7	15.4	7.6	14.25
FSP-311B-S-L7	40	22.2	15.9	16.1	32.8	20	21.7	15.4	7.6	15.3
FSP-311B-D-L2/L3	40	22.2	15.9	16.1	32.7	20	21.7	15.4	7.6	15.2
FSP-311B-D-L7	40	22.2	15.9	16.1	34.7	20	21.7	15.4	7.6	16.3
FSP-321B	40	19.25	12.7	11.7	26.3	20	18.8	12.3	5.3	12
FSP-321B-S-L2/L3	40	22.2	15.9	16.1	31	20	21.7	15.4	7.6	14.4
FSP-321B-S-L7	40	22.2	15.9	16.1	33.1	20	21.7	15.4	7.6	15.4
FSP-321B-D-L2/L3	40	22.2	15.9	16.1	33	20	21.7	15.4	7.6	15.4
FSP-321B-D-L7	40	22.2	15.9	16.1	35	20	21.7	15.4	7.6	16.4

Catalog #	Color	Description	Voltage
<input type="checkbox"/> FSP-301B	White	Fixture mount, passive infrared motion sensor, low voltage	12-32 VDC
<input type="checkbox"/> FSP-311B	White	Fixture mount, passive infrared motion sensor	120-277VAC, 50/60Hz
<input type="checkbox"/> FSP-321B	White	Fixture mount PIR sensor, extended voltage	100-347VAC or 208/230/480VAC
<input type="checkbox"/> FSP-L2	White	360° lens, maximum coverage 48' diameter from 8' height	
<input type="checkbox"/> FSP-L2-B	Black		
<input type="checkbox"/> FSP-L2-BR	Bronze		
<input type="checkbox"/> FSP-L2-G	Gray		
<input type="checkbox"/> FSP-L2-S	White	360° lens, maximum coverage 48' diameter from 8' height, with shroud; Minimizes high-angle light contribution to photocell	
<input type="checkbox"/> FSP-L3	White	360° lens, maximum coverage 40' diameter from 20' height	
<input type="checkbox"/> FSP-L3-B	Black		
<input type="checkbox"/> FSP-L3-BR	Bronze		
<input type="checkbox"/> FSP-L3-G	Gray		
<input type="checkbox"/> FSP-L3-S	White	360° lens, maximum coverage 40' diameter from 20' height, with shroud; Minimizes high-angle light contribution to photocell	
<input type="checkbox"/> FSP-L7	White	360° lens, maximum coverage 100' diameter from 40' height	
<input type="checkbox"/> FSP-L7-B	Black		
<input type="checkbox"/> FSP-L7-BR	Bronze		
<input type="checkbox"/> FSP-L7-G	Gray		
<input type="checkbox"/> FSP-L7-S	White	360° lens, maximum coverage 100' diameter from 40' height, with shroud; Minimizes high-angle light contribution to photocell	
<input type="checkbox"/> FSP-C1-W	White	Small collar, for use with FSP-L2 and FSP-L3 lenses (Optional aesthetic collar to transition from fixture housing to lens) Note: Not used with lenses that include shroud	
<input type="checkbox"/> FSP-C2-W	White	Large collar, for use with FSP-L7 lens (Optional aesthetic collar to transition from fixture housing to lens) Note: Not used with lens that includes shroud	

NOTE: Unless used with a driver or ballast with a low voltage power supply, the FSP-301B requires a Wattstopper power pack (ordered separately) to operate.

FSP-Lx series lens required for operation; order lens separately.

Smartphone commissioning application required for configuration. Download separately.

To order -S or -D model sensor, select one option from each column below and combine part numbers (as an example, FSP-201B-S-L2-W).

Pole or Box Mount Sensor Voltage	Nipple Configuration	Lens Option	Color
<input type="checkbox"/> FSP-301B, 12-32VDC sensor	<input type="checkbox"/> -S, Straight Nipple	<input type="checkbox"/> -L2, 360° lens, max coverage 48'diameter from 8' height	<input type="checkbox"/> -W, White
<input type="checkbox"/> FSP-311B, 120-277VAC sensor	<input type="checkbox"/> -D, Drop Nipple	<input type="checkbox"/> -L3, 360° lens, max coverage 40'diameter from 20' height	<input type="checkbox"/> -B, Black
<input type="checkbox"/> FSP-321B, 100-347VAC or 208/230/480VAC sensor		<input type="checkbox"/> -L7, 360° lens, max coverage 100'diameter from 40' height	<input type="checkbox"/> -BR, Bronze
			<input type="checkbox"/> -G, Gray

The Bluetooth® word mark and logos are registered trademarks owned by the Bluetooth SIG, Inc. and any use of such marks by Wattstopper is under license. Google Play and the Google Play logo are trademarks of Google Inc. The Apple logo, iPhone, iPod touch, and iTunes are trademarks of Apple Inc., registered in the U.S. and other countries.

Information supplied above is subject to change.
 Harmonization code: 8538908080. Country of origin: China.

26565r7 Rev 12/2025