

**8-RELAY CAPACITY  
LP8 RELAY PANEL**

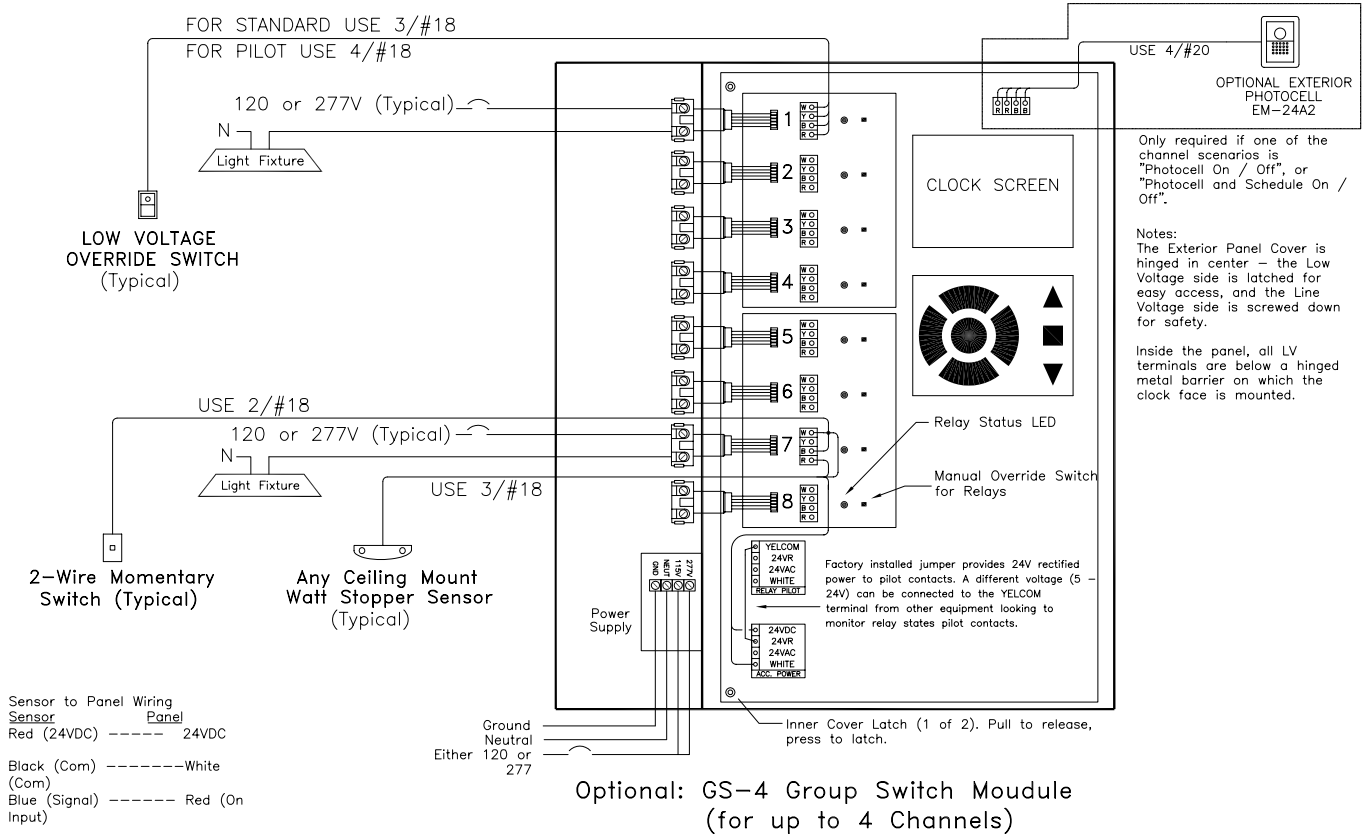

Lighting Control Panel Schedule

LCP Name:	LCP 1			
Location:	Electric Room xxx			
Surface/Flush:	Surface			
Power Circuit:	LA-42			
Relay #	Circuit	Description	LV Switch/Sensor	Channel
1	LA-1	Sample Text 1	LV Switch 1	A
2	LA-3	Sample Text 2	LV Switch 2	B
3	LA-5	Sample Text 3	LV Switch 3	C
4	LA-7	Sample Text 4	LV Switch 4	D
5	LA-2	Sample Text 5	LV Switch 5	E
6	LA-4	Sample Text 6	LV Switch 6	F
7	LA-6	Sample Text 7	LV Switch 7	G
8	LA-8	Sample Text 8	LV Switch 8	H

LCP Channel Automation Schedule

Channel	Scenario*	Scenario Times	Blink	Time Delay
A				
B				
C				
D				
E				
F				
G				
H				

**\*Scenario Listings**

- (1) Manual On / Sched Off
- (2) Scheduled On/Off
- (3) Manual ON / AS Switch Off
- (4) Photocell On/Off
- (5) Photo & Sched On/Off
- (6) Astronomic On/Off
- (7) Astro and Sched On/Off

**Specifications:**

Provide a single relay panel with up to 8 relays. Each relay to be individually scheduled through an easy to use integral clock with a backlit 8-line LCD display. Relays are to be SPST 20 Amp rated, mechanically held contactors capable of switching either 120 or 277VAC loads. Mounted next to each relay should be a LED to annunciate status and a pushbutton to toggle the relay's state. Panel shall have a multitap transformer and accept either 120V or 277V for power.

Panel enclosure to be NEMA 1, rated for environments from 32 - 139°F, 5 - 95% RH non-condensing. Panel to come with a split cover hinged in the center such that the high voltage side must be unscrewed to access the relays, but the low voltage side can be opened via a locking latch. Surface or flush covers shall be available.

Each relay can be controlled remotely by external switches or motion detectors. Switches can be 2- or 3-wire, momentary or maintained low voltage devices. Motion detectors must provide a 24VDC pilot signal to control the relays. Panel must be able to interlock time based schedules with the occupancy sensor input, so that lights scheduled on during the day are not affected by the motion detector, but after hours the occupancy sensor has control of the relay. Panel shall be capable of blink warning before "OFF" and true after hours time delay.

All programming to be entered via a simple keypad. Each relay can be programmed independently, or relays can be grouped together in firmware to follow the same channel schedule. On a daily 7-day repeating basis, relays can be assigned to follow any of the following scenarios:

- (1) Manual On / Sched Off
- (2) Scheduled On/Off
- (3) Manual ON / AS Switch Off (for use with AS-100 switches)
- (4) Photocell On/Off
- (5) Photo & Sched On/Off
- (6) Astronomic On/Off
- (7) Astro and Sched On/Off

The LCD screen should normally show the current time and date, as well as sunrise and sunset times for that day. Relay channels can also be monitored from the display to see their status - either ON, OFF, or MIXED. Additionally the relay groups can be overridden from the screen. Context sensitive help shall be available for each screen.

Panel to be The Watt Stopper's (800-852-2778) LP8 panel and must be UL Listed 916, meet local energy codes (California CEC), and have a 1 year warranty.

<b>Watt Stopper/Legrand</b>			
800-879-8585			
Title		Typical LP-8 Relay Panel Connections and Schedules	
Scale	Drawing#	Date	Rev.
None	60-852	01/27/06	1